

مهلت دریافت پروپوزال پژوهشی برای این پروژه از تاریخ ۱۳۹۶/۱۲/۰۱ لغایت ۱۳۹۷/۰۳/۰۱ می باشد.

۱- شماره RFP مربوط به پروژه:

شماره: تاریخ: مدیریت متقاضی:

۲- عنوان کامل پروژه:

۱-۲- زبان فارسی : طراحی و ساخت سیستم پایش محافظت در برابر لرزش و سنسورهای مرتبط برای ماشین آلات دوار  
براساس استاندارد API 670

۲-۲- زبان انگلیسی : Design and Manufacturing of Vibration Monitoring& Protection System  
and Related Sensors for Rotating Machineries According to API 670

۳- نوع پروژه: بنیادی  کاربردی  توسعه‌ای  بومی سازی و ساخت تجهیزات و قطعات  غیره

۴- تخمین مدت اجرای پروژه  (ماه)

۵- آیا این پروژه ادامه پروژه یا طرح دیگری می باشد؟  
آری  خیر   
(در صورت مثبت بودن پاسخ، بصورت اختصار پروژه / طرح قبلی معرفی گردد)

۶- مشخصات موضوعی پروژه:

۱-۶- شرح کلی پروژه:

بومی سازی و ساخت سیستم پایش و محافظت در برابر لرزش و سنسورهای مرتبط برای ماشین آلات دوار به منظور قطع وابستگی به شرکت های خارجی در این زمینه و صرفه جویی در سرمایه های ارزی کشور.

۲-۶- اهداف پروژه :

۱. تدوین دانش فنی و ساخت سنسورها، سیستم پایش و محافظت در برابر لرزش

۲. کاهش وابستگی به کشورهای خارجی

۳. صرفه جویی در سرمایه های ارزی کشور

۴. حمایت از شرکتهای سازنده داخلی در این زمینه

### ۳-۶- ضرورت اجرای پروژه :

با توجه به اینکه ماشین آلات دوار از جمله تجهیزات حساس و پر ارزش در چرخه تولید بوده و در نظر گرفتن مواردی مانند: ۱. تکنولوژی پایش و محافظت ماشین در برابر لرزش در رده محافظتهای بسیار حساس و منحصر بفرد. ۲. اطلاعات مربوط به لرزش یکی از پارامترهای مهم در شناسایی و جلوگیری از بروز عیوب بالقوه و در نتیجه کاهش زمان توقف ماشین آلات می باشد. ۳. محدودیت در تامین کالاهای این مقوله به دلیل کاربردهای چند گانه و....، ایجاب می نماید که انجام پروژه و تولید محصول بومی در این زمینه دارای اهمیت فراوانی باشد.

### ۴-۶- ملزومات اجرای پروژه :

۱- آخرین ویرایش استاندارد API670 در زمان عقد قرارداد می بایست به عنوان مرجع در نظر گرفته شود. بنابراین مشخصات کلیه کارت های ساخته شده می بایست مطابق با دیتاشیت های پیوست و این استاندارد باشد. در خصوص سنسورها، در درجه اول P/N ها و کاتالوگ های پیوست شده و سپس این استاندارد می بایست به عنوان مرجع در نظر گرفته شود. تاکید می گردد سنسورهای ساخته شده، با سنسورهای موجود بر روی ماشین آلات تعویض می گردند؛ بنابراین سنسورهایی که ساخته می شوند از نظر مشخصات کاملاً مشابه سنسورهای موجود باشند و نبایستی تصور کرد که در خصوص سنسورها مهندسی معکوس انجام می شود. لازم به ذکر است کلیه مراحل اجرای پروژه جهت سنسورها از قبیل طراحی و تولید مدارک فنی، شبیه سازی و .... می بایست توسط مجری و با نظارت کارفرما صورت پذیرد.

۲- تعداد و نوع سنسورها و کارت های مورد نیاز پیوست گردیده است (پیوست ۱) سنسورها می بایست مطابق P/N ها و کاتالوگ های پیوست ساخته شوند و کارتها نیز می بایست مطابق دیتاشیت های پیوست (پیوست ۲) ساخته شوند. لازم به ذکر است در صورتی که بین مشخصات ذکر شده در این فرم و لیست های پیوست با API670 مغایرتی وجود داشته باشد، این فرم و لیست های پیوست می بایست ملاک عمل قرار گیرند. بدیهی است در مواردی که در این فرم و لیست های پیوست مطلبی درج نشده است، استاندارد API670 ملاک عمل می باشد.

۳- جهت پیکره بندی سیستم لرزش نرم افزار به همراه لایسنس نامحدود ارائه گردد. این نرم افزار حداقل قابلیت کارکرد تحت ویندوز ۷ و XP و همچنین امکان Upload از سیستم را داشته باشد.

۴- کلیه تجهیزاتی که در محیط بیرون نصب می شوند دارای IP65 باشند.

۵- کلیه سنسورها دارای مشخصه Ex ia IIC T6 باشند.

۶- سیستم امکان ارتباط با سایر سیستم ها (از قبیل PLC و.....) از طریق پروتکل های مد باس و اترنت (از طریق Gateway Card) را داشته باشد.

۷- رک سیستم لرزش می بایست بصورت Rail Mount, Panel Mount باشد.

۸- رک سیستم لرزش شامل ۱۵-۱۸ اسلات (با قابلیت پوشش دهی ۱۵-۱۸ کارت) باشد.

۹- طول رک حداکثر ۶۰ سانتی متر باشد.

۱۰- کارت Power Supply حداقل ۲ عدد و بصورت Hot Redundant باشد.

۱۱- هر کانال کارت مربوط به سنسورهای لرزش قابلیت اتصال به هر سه نوع سنسور Velocity, Acceleration, Proximity و انتخاب نمایش نوع لرزش های Velocity, Trust, Displyment, Acceleration را داشته باشد.

- ۱۲- قابلیت تغییر Setpoint های Alarm و Danger در سرتاسر محدوده اندازه گیری یک کانال فراهم گردد.
- ۱۳- در حالت نوع سنسور Acceleration, بایستی قابلیت انتقال گیری و تبدیل سیگنال به Velocity در کانال فراهم باشد.
- ۱۴- جهت کارتهای لرزش فیلترهای بالا گذر و پایین گذر با قابلیت تنظیم فرکانس قطع در سرتا سر محدوده فرکانسی کارت را داشته باشد. ضمناً قابلیت فعال یا غیر فعال کردن این فیلترها در نرم افزار پیکره بندی سیستم لرزش وجود داشته باشد.
- ۱۵- قابلیت Bypass شدن هر کانال وکل سیستم لرزش می بایست فراهم شود. بدین منظور ترمینال هایی در پشت کارت ها در نظر گرفته شود که با Jumper کردن آنها Bypass فعال شده و در صورت برداشته شدن Jumper, Bypass غیر فعال شود.
- ۱۶- قابلیت Multiply کردن Setpoint برای هر کانال در نظر گرفته شود.
- ۱۷- علاوه بر کارتهای ذکر شده در API670 یک کارت تحت عنوان Rack Interface Module جهت انجام دانلود و آپلود پیکره بندی در سیستم وجود داشته باشد.
- ۱۸- تستها و تجهیزات مورد نیاز جهت تست مطابق پیوست ۳ ارائه گردد. لازم به ذکر است که مجری میبایست مدرکی با عنوان Test Procedure تهیه نموده و پس از تأیید این مدرک توسط کارفرما، تستهای آزمایشگاهی و میدانی بر اساس آن انجام شود.
- ۱۹- علاوه بر مواردی که در پیوست مربوط به تست ذکر شده است، مجری میبایست تجهیزات و اقدامات لازم جهت تست سنسورها و سیستم در سرتاسر بازه رطوبتی و دمایی ذکر شده در دیتا شیت را فراهم سازد. لازم به ذکر است که تجهیزات به مدت حداقل ۷۲ ساعت در شرایط رطوبتی و دمایی مورد نظر قرار گرفته و تست شوند.
- ۲۰- سیستم میبایست قابلیت اضافه کردن کارتهای Over Speed و دما را (در آینده) داشته باشد.
- ۵-۶- اثربخشی پروژه:**
- با اجرای این پروژه محدودیت هایی که در زمینه تامین سیستم های لرزش و سنسورهای مربوط به آنها وجود دارد برطرف شده و گام مهمی در رفع مشکلات و معضلات پروژه های داخلی از قبیل گارانتی، پشتیبانی فنی و تامین قطعات یدکی برداشته شده و کشور را به خودکفایی صنعتی نزدیک تر می نماید. همچنین با اندازه گیری لرزش که یکی از پارامترهای مهم در شناسایی و جلوگیری از بروز عیوب بالقوه ماشین آلات می باشد، زمان توقف ماشین آلات کاهش می یابد.
- ۶-۶- سوالات، ابهامات و انتظارات اصلی که میبایست در این پروژه پژوهشی مورد بررسی قرار گیرد:**
- ۱- بررسی انواع سنسورهای لرزش و مقایسه مزایا و معایب آنها.
  - ۲- بررسی روشهای جدید و تکنولوژی های جدید جهت اندازه گیری سیگنال های لرزش.
  - ۳- پیشنهاد روش هایی جهت آنالیز سیگنال های لرزش به منظور عیب یابی و برنامه ریزی تعمیرات پیشگیرانه.
- ۷-۶- پیش بینی مراحل اجرای پروژه : ( در صورت امکان)**
- ۱- بررسی تاریخچه کارهای انجام شده در این زمینه
  - ۲- ارائه کلیه مدارک طراحی مورد نیاز
  - ۳- شبیه سازی سنسورها و سیستم
  - ۴- ساخت تجهیزات
  - ۵- انجام تست آزمایشگاهی و صحت سنجی

۶- انجام تست میدانی

لازم به ذکر است که کلیه مراحل می بایست با هماهنگی، نظارت و تایید شرکت ملی مناطق نفتخیز جنوب صورت پذیرد.

۶-۸- سوابق فعالیت‌های مشابه با پروژه در داخل و یا خارج از کشور: (در صورت امکان)

۷- براساس بررسی‌های بعمل آمده، مدت زمان لازم جهت اخذ پروپزال پژوهشی از طریق سایت پژوهش از مراکز تحقیقاتی حداکثر **۳ ماه** تعیین گردیده است.

۸- پیش بینی خدمات مورد نیاز که می بایست توسط مناطق نفتخیز جنوب در اختیار پروژه قرار گیرد:  
صدرو مجوز تردد برای دست اندرکاران پیمانکار و در اختیار گذاشتن برخی اطلاعات مورد نیاز ماشین آلات.

۹- کلیه ادارات / ارگانها و سازمانها غیر از شرکت ملی مناطق نفتخیز جنوب که احتمالاً از نتایج این تحقیق استفاده می نمایند :  
تمامی شرکت های تابعه وزارت نفت و شرکت های متفرقه که از این سیستم و سنسورها جهت حفاظت ماشین آلات دوار استفاده می کنند.

۱۰- سایر اقدامات و اطلاعات موردنیاز مجری جهت تهیه پروپزال پژوهشی بنا به تشخیص اداره متقاضی و تأیید گروه تخصصی:

در صورت نیاز مجری به اطلاعات میدانی و کارکرد ماشین آلات دوار و سنسورهای مرتبط، اطلاعات مربوطه می بایست در اختیار ایشان قرار گیرد.

۱۱- جهت رفع ابهامات احتمالی فنی مراکز علمی و تحقیقاتی، افراد و مشخصات ذیل از طرف اداره متقاضی تعیین شده اند. (در صورت تشخیص اداره متقاضی و گروه تخصصی)

گروه تخصصی: فرآورش نفت و گاز

نام و نام خانوادگی	شماره تماس	آدرس ایمیل	زمان پاسخگویی به سئوالات
(۱) محمدرضا مقدمیان	۳۴۱۲۴۵۶۵		



# فرم داوری پیشنهاد طرح / پروژه پژوهشی



شرکت ملی نفت ایران  
شرکت ملی مناطق نفتخیز جنوب (سهامی خاص)

عنوان پیشنهاد طرح / پروژه (پروپزال): طراحی و ساخت سیستم پایش محافظت در برابر لرزش و سنسورهای مرتبط برای ماشین آلات دوار براساس استاندارد API 670

توضیحات	امتیاز مؤثر (امتیاز × ضریب وزنی)	امتیاز (۰ تا ۱۰۰)	ضریب وزنی مؤثر (۰ تا ۵)	شاخصهای داوری
			۵	۱- سوابق اجرایی سازمان پیشنهاد دهنده پروپزال
			۵	۲- توانایی پرسنلی تیم مجری ( تخصص/تحصیلات/ تجربه کاری)
			۳	۳- جامع نگری مسئله در پروپزال
			۴	۴- هدف گذاری مناسب و روش حل مسئله
			۴	۵- شفافیت مراحل اجرا در جدول زمانبندی
			۵	۶- امکانات و تجهیزات مجری برای انجام پروژه
			۳	۷- میزان شفافیت برآورد هزینه ها
			۳	۸- توان مالی و پشتیبانی سازمان پیشنهاد دهنده پروپزال
	آیتم های ۹ و ۱۰ توسط اداره پژوهش تکمیل میگردد		-	۹- امتیاز ویژه ایده اولیه پروپزال
			۴	۱۰- امتیاز حسن سابقه فعالیتهای پژوهشی قبلی با مناطق
۱۱- بطور کلی مجری توانایی انجام پروژه را: <input type="checkbox"/> دارد <input type="checkbox"/> ندارد				

نام سازمان پیشنهاد دهنده طرح / پروژه ( مجری):

نقطه نظر کلی داور در خصوص پروپزال و مجری:

امتیاز نهائی:

نام و نام خانوادگی داور:

امضاء:

تاریخ:

پیوست ۱:

لیست سنسورها و کارتهای مورد نیاز:

	Type	P/N	Quantity
Sensor	Proximity Probe	330101-00-12-10-02-05 (Bently Nevada)	2
	Proximity Probe	330101-00-12-20-02-05 (Bently Nevada)	2
	Extension Cable	330130-080-00-05 (Bently Nevada)	2
	Extension Cable	330130-070-00-05 (Bently Nevada)	2
	Proximitior	330180-91-05 (Bently Nevada)	2
	Acceleration	330400-AA <sup>(Note1)</sup> -05 (Bently Nevada)	2
	Acceleration	330450-40 (Bently Nevada)	2
	Velocity	330525-02 (Bently Nevada)	2
	Velocity	5485C-003-010 Metrix	2
Card	Power Supply	-	4
	Rack Interface Module	-	2
	Proximity/Acceleration/Velocity	-	4
	Keyphasor	-	2
	Relay (4 channel)	-	2
	Relay (16 channel)	-	2
	Gateway	-	2

Note1: This option will be specified later.

<b>Rack Interface Module</b>		
Power Consumption	<6 Watts	
Input System Contacts	Trip Multiply, Alarm Inhibit, Rack Reset	
Communication	Physical Layer:Rs232,422	
	Baud rate>19.2kbps	
Noise Immunity& Radiation	According to EN61000	
Operating Temperature	-30~65°C	
Storage Temperature	-40~85°C	
Humidity	95%,non-condensing	
Physical	Height: < 250mm	
	Width: < 30mm	
	Depth: < 300mm	
	Weight: < 0.7kg	

<b>Power Supply Card</b>		
Input Voltage	110 VAC±10% ~50Hz 24VDC ±10%	Shall be Selectable
Noise Immunity& Radiation	According to EN61000	
Operating Temperature	-30~65°C	
Storage Temperature	-40~85°C	
Humidity	95%,non-condensing	
Redundancy	Yes, 2 Power Supply Cards	Power Supply Shall be Hot Redundant
Physical	Height: < 250mm	
	Width: < 100mm	
	Depth: < 300mm	
	Weight: < 1.5kg	

<b>Proximity/ Acceleration/Velocity Card</b>		
<i>Inputs</i>		
Number of Channels	4	
Type of Sensor for Channels	Proximity/ Acceleration/Velocity Selectable for Each Channel	
Input Impedance	> 10k $\Omega$	
Power Consumption	<10 Watts	
Sensitivity	Proximity: 200mV/mils and 100mV/mils	Shall be Adjustable
	Acceleration: 100mV/g	Shall be Adjustable
	Velocity: 100mV/(in/s) and 145mV/(in/s)	Shall be Adjustable
<i>Outputs</i>		
Front Panel LEDs	Ok LED, Bypass LED	
Buffered Transducer Outputs	YES, for Each Channel	
Analog 4-20 mA Output	YES, for Each Channel	
Output Impedance	<600 $\Omega$	
Transducer Power Supply	-24Vdc	
<i>Signal Conditioning</i>		
Frequency Response(3db)	Proximity:0 to 15kHz	
	Acceleration:5 to 30kHz	
	Velocity: 5 to 30kHz	
Accuracy	0.4% Full Scale	
Noise Immunity& Radiation	According to EN61000	
Operating Temperature	-30~65 $^{\circ}$ C	
Storage Temperature	-40~85 $^{\circ}$ C	
Humidity	95%,non-condensing	
Physical	Height < 250mm	
	Width< 30mm	
	Depth< 300mm	
	Weight< 0.5kg	

**Keyphasor Card***Inputs*

Number of Channels	2	
Type of Sensor for Channels	Proximity/Magnetic Pickup Selectable for Each Channel	
Input Impedance	> 22k $\Omega$	
Power Consumption	<5 Watts	

*Outputs*

Front Panel LEDs	Ok LED, Bypass LED	
Buffered Transducer Outputs	YES, for Each Channel	
Output Impedance	<600 $\Omega$	
Transducer Power Supply	-24Vdc	

*Signal Conditioning*

Frequency Signal Ranges	0 to 40kHz	
Accuracy	0.4% Full Scale	
Noise Immunity& Radiation	According to EN61000	

Operating Temperature	-30~65°C	
Storage Temperature	-40~85°C	
Humidity	95%,non-condensing	
Physical	Height < 250mm	
	Width< 30mm	
	Depth< 300mm	
	Weight< 0.5kg	

<b>Relay Card</b>		
Power Consumption	<6 Watts	
<i>Outputs</i>		
Number of Channels	4&16	
Front Panel LEDs	Ok LED, Channel Alarm LED	
<i>Relays</i>		
Types	SPDT (Single pole-double throw)	Normally Energized or Normally De-energized Shall be Selectable for each Channel
Noise Immunity& Radiation	According to EN61000	
<i>Operating Temperature</i>		
Operating Temperature	-30~65°C	
Storage Temperature	-40~85°C	
<i>Humidity</i>		
Humidity	95%,non-condensing	
<i>Physical</i>		
Physical	Height < 250mm	
	Width< 30mm	
	Depth< 300mm	
	Weight< 0.5kg	

<b>Gateway Card</b>		
<i>Inputs</i>		
Power Consumption	<5 Watts	
<i>Outputs</i>		
Front Panel LEDs	Ok LED, TX/RX LED	
Ports	2(1 Modbus, 1 Ethernet)	
<i>Protocols</i>	Modbus RTU(RS232,422,485)	
	Ethernet, 10Mbps	
Noise Immunity& Radiation	According to EN61000	
Operating Temperature	-30~65°C	
Storage Temperature	-40~85°C	
Humidity	95%,non-condensing	
Physical	Height < 250mm	
	Width< 30mm	
	Depth< 300mm	
	Weight< 1kg	

## APPENDIX F—FIELD TESTING AND DOCUMENTATION REQUIREMENTS

### F.1 General

**F.1.1** This appendix outlines minimum field testing and documentation requirements for machinery protection system components. It is intended as a convenience to the purchaser and the owner in clearly specifying the total job requirements.

**F.1.2** Verification and documentation shall be submitted to the owner as follows:

- a. Machinery vendors shall submit documentation at least 2 weeks prior to any factory mechanical testing.
- b. Construction agencies shall submit documentation at least 4 weeks prior to machine start-up.

### F.2 Tools and Instrumentation

The codes in Table F-1 are used to designate tools and instruments needed to calibrate and test various portions of the machinery protection system.

### F.3 Vendor Requirements

The purchaser shall use the form in Table F-2 to indicate the required activities and the responsible agency or vendor required to perform each specified activity.

Table F-1—Tools and Instruments Needed to Calibrate and Test Machinery Protection Systems

Code	Tool or Instrument	Typical Application
A	DC voltage nulling instrument	Shaft electrical and mechanical runout testing and documentation
B	Analog X-Y plotter or dual channel storage oscilloscope with digital plotter and required software	Shaft electrical and mechanical runout testing and documentation
C	Proximity probe calibration test kit	System calibration, functional, and accuracy testing
D	Calibrated digital multimeter and frequency measuring device	System calibration, functional, and accuracy testing
E	Variable frequency waveform and pulse generator with DC offset	Simulation testing for vibration, position, tachometer, and overspeed detection channels
F	Variable frequency shaker with calibrated reference accelerometer	Accelerometer and Velocity testing
G	Oscilloscope	Simulation testing for vibration, position, tachometer, and overspeed detection channels
H	Temperature sensor simulator	Simulation testing for temperature channels

Table F-2—Data, Drawing, and Test Worksheet

Directions:

- I – Activity item number
- R – An X in this box indicates a required activity to be performed by the machinery protection system vendor.
- M – An X in this box indicates a required activity to be performed by the machinery vendor.
- C – An X in this box indicates a required activity to be performed by the construction agency.
- O – An X in this box indicates a required activity to be performed by other agency; specify agency.

I	R	M	C	O	Activity	Tool and Instrument Codes <sup>a</sup> (Paragraph Reference)
1					Location of rotor nodal points	(6.1.1.1 Items e and f, Table G-2 Item 6)
2					Electrical/mechanical runout documentation	A, B, C, D (6.1.1.3, 6.1.1.3, 6.1.2.4, Table G-2 Item 5)
3	X				Calibration curve for each proximity probe transducer	C, D (7.6.2.1, Table G-2 Item 5)
4	X				Acceleration or velocity shaker test	D, E, F (7.6.2.3, Table G-2 Item 5)
5	X				System arrangement plan	(Table G-2 Item 4)
6	X				Monitor system calibration check	C, D, E, F, H (4.5, 7.6.2, Table G-2 Item 19g)
7					Recommended alarm and shutdown setpoints	(Table G-2 Item 7)
7.1					Shaft vibration	(Table G-2 Item 7)
7.2					Shaft axial position	(Table G-2 Item 7)
7.3					Radial bearing temperature	(Table G-2 Item 7)
7.4					Thrust bearing temperature	(Table G-2 Item 7)
7.5					Casing acceleration	(Table G-2 Item 7)
7.6					Casing Velocity	(Table G-2 Item 7)
7.7					Piston Rod Drop	(Table G-2 Item 7)
7.8					Overspeed Detection	(Table G-2 Item 7)
8	X				Operation for hazardous area compliance testing	(5.7)
9	X				Channel accuracy test	C, D, E, F, H (Table 1)
9.1	X				Radial shaft vibration	C, D, E (Table 1, 7.6.2.1)
9.2	X				Axial position	C, D, E (Table 1, 7.6.2.1)
9.3	X				Casing Vibration	D, E, F (Table 1, 7.6.2.3)
9.4					Temperature	D, H (Table 1, 7.6.2.2)
9.5	X				Piston Rod Drop	C, D, E (Table 1, 7.6.2.1)
9.6					Overspeed Detection	D, E (Table 1, 7.6.2.4)
10	X				Buffered output versus input accuracy	C, D, E, F (Table 1, 5.4.1.4 Item c, 7.6.2)

Provided by: www.spic.ir Licensee: NISOC Library

Table F-2—Data, Drawing, and Test Worksheet (Continued)

Directions:

- I – Activity item number
- R – An X in this box indicates a required activity to be performed by the machinery protection system vendor.
- M – An X in this box indicates a required activity to be performed by the machinery vendor.
- C – An X in this box indicates a required activity to be performed by the construction agency.
- O – An X in this box indicates a required activity to be performed by other agency; specify agency.

I	R	M	C	O	Activity	Tool and Instrument Codes <sup>a</sup> (Paragraph Reference)
11	X				Power supply short-circuit test	D (5.4.1.7 Item d, 7.6.1)
12	X				Output relay tests	(7.6.1)
12.1	X				Circuit fault	C, D, E (5.4.1.3 Item a, 5.4.1.8 Item f, 5.4.2.2, 5.4.3.2, 5.4.4.5, 5.4.5.3, 5.4.6.2, 7.6.1)
12.2	X				Shaft axial position alarm	C, D, E (5.4.1.5 Item a, 5.4.3.3, 7.6.1)
12.3	X				Shaft axial position shutdown	C, D, E (5.4.1.5 Item a, 5.4.3.3, 5.4.3.4, 7.6.1)
12.4	X				Radial shaft vibration alarm	C, D, E (5.4.1.5 Item a, 5.4.2.4, 5.4.2.5, 7.6.1)
12.5	X				Radial shaft vibration shutdown	C, D, E (5.4.1.5 Item a, 5.4.2.4, 5.4.2.5, 7.6.1)
12.6	X				Casing vibration alarm	D, E, F (5.4.1.5 Item a, 5.4.5.4, 7.6.1)
12.7	X				Casing vibration shutdown	D, E, F (5.4.1.5 Item a, 5.4.5.4, 7.6.1)
12.8					Temperature alarm	D, H (5.4.1.5 Item a, 7.6.1)
12.9					Temperature shutdown	D, H (5.4.1.5. Item a, 5.4.6.4, 7.6.1)
12.10	X				Piston Rod Drop alarm	C, D, E (5.4.1.5 Item a, 7.6.1)
12.11	X				Piston Rod Drop shutdown	C, D, E (5.4.1.5 Item a, 5.4.4.6, 7.6.1)
12.12					Overspeed Detection alarm	D, E, G (5.4.1.8 Item b, 5.4.8.4 Items c and e, 7.6.1)
13	X				System Inhibit and Channel Bypass Test	D, E, G
14	X				System shutdown disarm test	C, D, E (5.4.1.9, 7.6.1)
15	X				Communication interface Functional test	C, D, E, F, G, H (5.4.1.10, 7.6.1)
15.1	X				Analog 4-20 mA outputs	C, D, E, F, H (5.4.1.4 Item f, 7.6.1)
15.2	X				Digital communications port	(5.4.1.4 Item e, 5.4.1.10, 7.6.1)
16	X				First out alarm and shutdown test	C, E, F, H (5.4.1.5 Item j, 7.6.1)
17	X				Circuit fault functional test	C, D, E (5.4.1.4 Item b, 7.6.1)
18	X				Shutdown system functional test	E, H (5.4.1.5 Item g, 5.4.1.6 Item b, 7.6.1)

Table F-2—Data, Drawing, and Test Worksheet (Continued)

## Directions:

- I – Activity item number  
 R – An X in this box indicates a required activity to be performed by the machinery protection system vendor.  
 M – An X in this box indicates a required activity to be performed by the machinery vendor.  
 C – An X in this box indicates a required activity to be performed by the construction agency.  
 O – An X in this box indicates a required activity to be performed by other agency; specify agency.

I	R	M	C	O	Activity	Tool and Instrument Codes <sup>a</sup> (Paragraph Reference)
19	X				Individual channel shutdown disarm test	C, D, E (5.4.1.5 Item h, 7.6.1)
20	X				Voting logic tests	(7.6.1)
20.1	X				Shaft axial position	D, E (5.4.3.4, 7.6.1)
20.2	X				Radial shaft vibration	D, E (5.4.2.4, 7.6.1)
20.3	X				Casing vibration	D, E (7.6.1)
20.4					Temperature	D, H (5.4.6.4, 7.6.1)
20.5	X				Piston Rod Drop	D, E (7.6.1)
21	X				Setpoint Multiplier Test	D, E (5.4.2.5 and 5.4.5.4)
22	X				Casing vibration filter cutoff frequency	D, E, (5.4.5.2, 7.6.1)
23					Temperature sensor downscale failure verification test	(5.4.6.2, 7.6.1)
24	X				System wiring signal loss test	D, E, G (7.6.1)
25	X				Wiring connection verification test	(7.6.1)
26	X				Radio transmission RFI verification test	(5.7.3)
27	X				System integration test	C, D, E, F, G (7.6.3)
28	X				Final system arrangement plan	(8.3.5.2, Table G-2 Item 10)

<sup>a</sup>Tool and instrument codes are listed in Table F-1.

# 330525 Velomitor\* XA Piezo-velocity Sensor

## Bently Nevada\* Asset Condition Monitoring

---

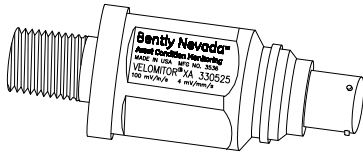

### Description

The Velomitor\* XA (eXtended Application) Sensor is a ruggedized version of Bently Nevada's 330500 Velomitor Sensor. Its 316L stainless steel case and unique, weatherproof connector and cable assembly permit mounting without a housing. The Velomitor XA Sensor cable assembly is suitable for use in moist environments, and the Velomitor XA Sensor design meets the requirements of IP-65 and NEMA 4X when properly installed with a mating extension cable.

### ⚠ Caution

If housing measurements are being made for overall protection, give thought to the usefulness of the measurement for each application. Most common machine malfunctions (imbalance, misalignment, etc.) originate at the rotor and cause an increase (or at least a change) in rotor vibration. For any housing measurement alone to be effective for overall machine protection, the system must faithfully transmit a significant amount of rotor vibration to the bearing housing or machine casing, or more specifically, to the mounting location of the transducer.

In addition, exercise care when choosing the physical installation of the transducer. Improper installation can change the transducer amplitude and frequency response and/or generate signals that do not represent actual machine vibration.

Upon request, we can provide engineering services to determine the appropriateness of housing measurements for the machine in question and/or to provide installation assistance.



---

## Specifications

Parameters are specified from +20 to +30 °C (+68 to +86 °F) and 100 Hz unless otherwise indicated.

**Note:** Operation outside the specified limits may result in false readings or loss of machine monitoring.

---

### Electrical

#### Sensitivity:

3.94mV/mm/s (100 mV/in/s) ±5%.

#### Frequency Response:

4.5 to 2,000 Hz (270 to 120,000 cpm) ±3.0 dB,

6.0 to 1,000 Hz (360 to 60,000 cpm) ±0.9 dB.

#### Temperature Sensitivity:

-14% to +7.5% typical over the operating temperature range.

#### Velocity Range:

1270 mm/s (50 in/s) peak.

#### Transverse Sensitivity:

Less than 5% of sensitivity.

#### Amplitude Linearity:

±2% to 152 mm/s (6 in/s) peak.

#### Mounted Resonant Frequency:

Greater than 12 kHz.

#### Broadband Noise Floor (4.5 Hz to 2 kHz):

0.004 mm/s (160 µin/s) rms, nominal.

#### Maximum cable length:

305 metres (1,000 feet) of cable, BN part number 02173007 with no degradation of signal.

---

## Hazardous Area Approvals

Multiple approvals for hazardous areas certified by Canadian Standards Association (CSA/NRTL/C) in North America and by LCIE in Europe.

### North America:

Ex ia IIC T4  
AEx ia IIC T4  
Class I, Div 1 Groups A, B, C & D  
Class II, Groups E, F, and G  
Class III  
T4 @ -40°C ≤ Ta ≤ 100°C

Ex nL IIC T4  
AEx nA IIC T4  
Class I, Div 2  
Groups A, B, C & D  
T4 @ -40°C ≤ Ta ≤ 100°C

Per DWG 167539

### European/ATEX:

 II 1 G Ex ia IIC T4  
T4 @ -40°C ≤ Ta ≤ 100°C

 II 3 G Ex nL IIC T4  
T4 @ -40°C ≤ Ta ≤ 100°C

### IECEX:

Ex ia IIC T4  
T4 @ -40°C ≤ Ta ≤ 100°C

Ex nL IIC T4  
T4 @ -40°C ≤ Ta ≤ 100°C

### Brazil:

BR-Ex ia IIC T4  
T4 @ -40°C ≤ Ta ≤ 100°C

For further certification and approvals information please visit the following website:

[http://www.ge-energy.com/prod\\_serv/products/oc/en/bently\\_nevada.htm](http://www.ge-energy.com/prod_serv/products/oc/en/bently_nevada.htm)

---

## Environmental Limits

### Operating Temperature Range:

-55 °C to +121 °C (-67°F to +250°F)

### Shock Survivability:

5000 g peak, maximum

Specifications and Ordering Information  
Part Number 141633-01  
Rev. G (03/10)

**Relative Humidity:**

To 100% non-submerged;  
case is hermetically-sealed.

**Magnetic Field Susceptibility:**

<51 µin/s/gauss (50 gauss, 50-60 Hz)

---

**Physical**

**Weight:**

156 g (5.5 oz), typical

**Diameter:**

28 mm (1.1 in)

**Height:**

73.1 mm (2.88 in)

**Case Material:**

316L stainless steel

**Connector:**

2-pin Mil-C-26482 hermetically-sealed, 304 stainless steel shell.

**Mounting Torque:**

45 N-m (33 ft-lb) maximum

**Polarity:**

Pin A goes positive with respect to pin B when the sensor case motion is toward the connector.

**Cable Bend Radius:**

1.5-in minimum bend radius.

**Note:** Please read and understand the User Manual *before* attempting to install and use this product.

---

**Ordering Options**

**Approvals**

**330525-AA**

**A: Agency Approval Option**

- 00** None Required
- 01** CSA/NRTL/C
- 02** SIRA/CENELEC

---

**Interconnect Cable**

**106765-AA**

**A:** Length in metres

**Minimum length:** 1 metre (3.3 feet)

**Maximum length:** 25 metres (82 feet)

Order in increments of 3 metres.

---

**Terminal Housing**

Terminal Housing for terminating Velomitor XA Sensor cable to bulk cable listed above. The Terminal Housing provides local connection of the Velomitor XA Sensor signal wires to the monitor field wiring. Each Terminal Housing can accommodate up to 2 Velomitor XA Sensor Cables.

**106769-AA**

**A: Conduit Fitting Option**

- 00** No fittings supplied
- 01** One ¾ NPT fitting
- 02** Two ¾ NPT fittings

---

**Accessories**

**100076-01**

330500 Velomitor Sensor and Velomitor XA Sensor Manual.

**02173007**

Bulk cable; 2 conductor twisted, shielded. 22 AWG cable without connectors or terminal lugs. Specify length in feet.

**103537-01**

Terminal Mounting Block. Provides simple field wiring connection and can be mounted inside any standard Proximitor® Sensor housing. One terminal mounting block is needed for each Velomitor XA Sensor connection.

**03839144**

Splash-resistant boot cover for interconnect cable assembly. The boot is made from fluorosilicone elastomer. Boot color is blue.

**03839142**

Bottom clamp used to secure the boot to the Velomitor XA Sensor case.

**03839143**

Top clamp used to secure the boot to the interconnect cable assembly.

# Graphs and Figures

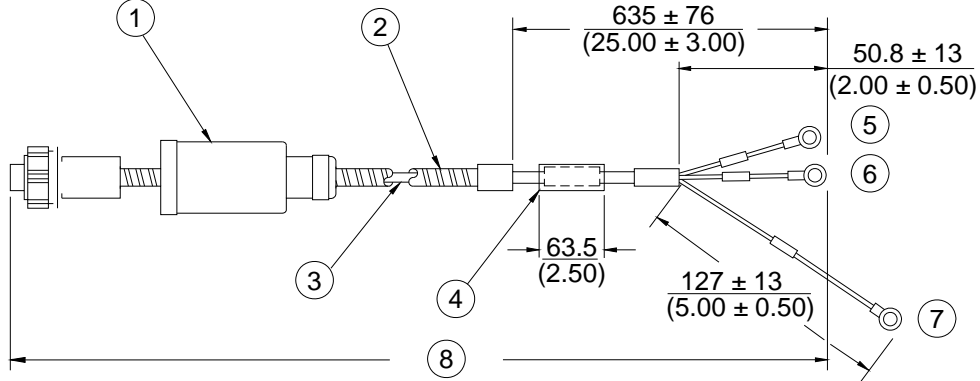

- |                                      |                               |
|--------------------------------------|-------------------------------|
| 1. Splash-resistant boot with clamps | 5. "A" (white)                |
| 2. Stainless steel armor over cable  | 6. "B" (black)                |
| 3. 0.382 mm <sup>2</sup> (22 AWG)    | 7. "SHLD" (green)             |
| 4. Clear shrink tubing               | 8. Overall length ± 200 (7.8) |

Figure 1: Dimensions for 106765 Cable Arial check all figure headings  
 Dimensions are in millimeters (inches)



# 330450 High Temperature Acceleration System

## Bently Nevada\* Asset Condition Monitoring

---

### Description

The standard 330400 Accelerometer has a limited temperature range it can be exposed to, due to its signal conditioning electronics being located in the same case as the sensing element. Temperature limitations of the electronics limit its maximum operating temperature to +121°C (+250°F).

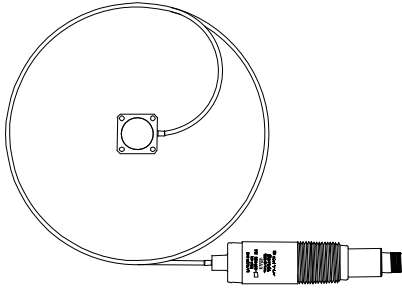

The 330450 High Temperature Acceleration System (HTAS) has a fundamentally different construction to solve this problem. Its design segregates the sensing element from the signal conditioning electronics, with the two permanently connected via a hardline cable. Current versions (see note below) of these sensors allow the sensing head to be mounted on surfaces with temperatures as high as +400°C (+752°F). Due to the segregated design, the signal conditioning electronics can be installed in a cooler location. This achieves overall transducer system performance comparable to other acceleration transducers, but permits use at significantly higher temperatures. By eliminating connections between the sensing head and its associated signal conditioning electronics, a significant source of potential transducer failures (connector problems) is eliminated.

### Caution

If housing measurements are being made for overall protection of the machine, thought should be given to the usefulness of the measurement for each application. Most common machine malfunctions (imbalance, misalignment, etc.) originate at the rotor and cause an increase (or at least a change) in rotor vibration. In order for any housing measurement alone to be effective for overall machine protection, a significant amount of rotor vibration must be faithfully transmitted to the bearing housing or machine casing, or more specifically, to the mounting location of the transducer.

In addition, care should be exercised in the physical installation of the transducer. Improper installation can result in a degradation of the transducer's performance, and/or the generation of signals which do not represent actual machine vibration.

Upon request, Bently Nevada can provide engineering services to determine the appropriateness of housing measurements for the machine in question and/or to provide installation assistance.

**Note:** The previous version limited the sensor head to +300°C (+572°F). The current versions will have the letter "G" preceding the serial number.



---

## Specifications

Parameters are specified from +20 to +30°C (+68 to +86°F) and 100Hz unless otherwise indicated.

**Note:** Operation outside the specified limits may result in false readings or loss of machine monitoring.

---

### Electrical

#### Sensitivity:

10.2 mV/m/s<sup>2</sup> (100 mV/g) ±5%.

#### Acceleration range:

785 m/s<sup>2</sup> (80 g) peak overall acceleration within the 15 to 10000 Hz frequency span.

#### Amplitude Linearity:

±2% to 785 m/s<sup>2</sup> (80 g) peak.

#### Broadband Noise Floor (10 Hz to 15 kHz):

0.059 m/s<sup>2</sup> (0.006 g) rms.

#### Frequency Response:

15 to 10000 Hz  
(900 to 600,000 cpm) ±3dB;  
40 to 4000 Hz  
(2400 to 240,000 cpm) ±5%

#### Transverse Sensitivity:

Less than 5% of axial.

#### Mounted Resonant Frequency:

Greater than 15 kHz.

#### Maximum cable length:

305 metres (1000 ft) with no degradation of signal.

#### Power requirements:

#### Input Voltage

-24 ± 0.5 Vdc.

#### Bias Current:

2 mA nominal.

#### Output Bias Voltage:

-12 ± 0.5 Vdc.

#### Grounding:

Case isolated.

---

## Hazardous Area Approvals

Multiple approvals for hazardous areas certified by Canadian Standards Association (CSA/US/C) in North America and by LCIE in Europe.

#### North America:

Ex ia/AEx ia for IIC T4  
Class I, Div 1  
Groups A, B, C, and D;  
Class II, Div 1, Groups E, F, and G;  
Class III, Div 1, when installed per drawing 168078.  
T4 @ Ta (- 40°C to 100°C)  
Enclosure Type 4X  
Ex nL IIC T4  
Class 1, Zone 2  
Class I, Div 2  
Groups A, B, C, and D when installed per drawing 168078.  
T4 @ Ta (- 40°C to 100°C)  
Enclosure Type 4X

#### ATEX:

 II 1 G  
EEx ia IIC T4  
Tamb.: - 40°C to 100°C

For further certification and approvals information please visit the following website:

[http://www.ge-energy.com/prod\\_serv/products/oc/en/bently\\_nevada.htm](http://www.ge-energy.com/prod_serv/products/oc/en/bently_nevada.htm)

---

## Environmental Limits

### Operating and storage temperature range

#### Sensing head:

Maximum mounted surface temperature –55°C to +400°C (–67°F to +752°F)

#### Integral hardline cable:

–55°C to +400°  
(–67°F to +752°F)

#### Electronics:

–55°C to +121°C  
(–67°F to +250°F)

#### Shock survivability:

24,535 m/s<sup>2</sup> (2500 g) peak

#### Relative humidity:

To 100% non-submerged; case is hermetically sealed.

---

## Physical

### Weight (typical):

#### 2 metres:

635 grams (1.40 lb)

#### 4 metres:

794 grams (1.75 lb)

#### 6 metres:

953 grams (2.10 lb)

#### 8 metres:

1111 grams (2.45 lb)

#### Mounting:

See Dimensional Drawing, Figure 1

#### Case material:

300 series stainless steel.

#### Connector:

3-pin Mil-C-5015 receptacle, hermetically-sealed, 304 stainless steel shell.

#### Polarity:

Pin A goes positive with respect to Pin C when the applied force is from the base to the top of the sensing head.

#### Bend Radius:

Minimum bend radius of 51mm (2.0in)

**Note:** Please read and understand the User Guide *before* attempting to install and use this product.

---

## Ordering Information

### 330450-AXX

#### A: Length

<b>20</b>	2 metres
<b>40</b>	4 metres
<b>60</b>	6 metres
<b>80</b>	8 metres

Graphs and Figures

Dimensional Drawing – 330450

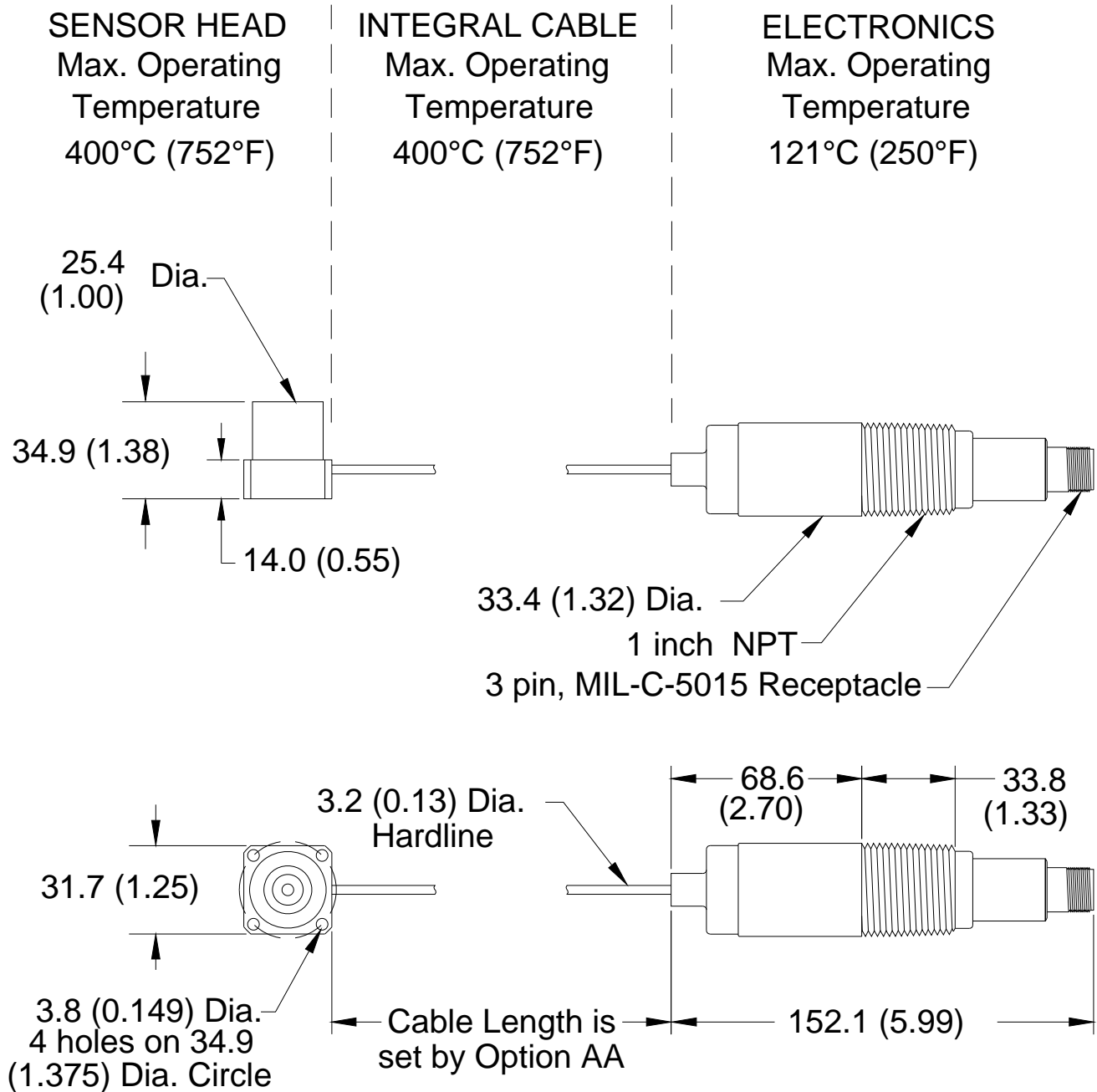

Figure 1: 330450 System Dimensional Drawing  
 Dimensions are in millimeters (inches)

# Graphs - 330450

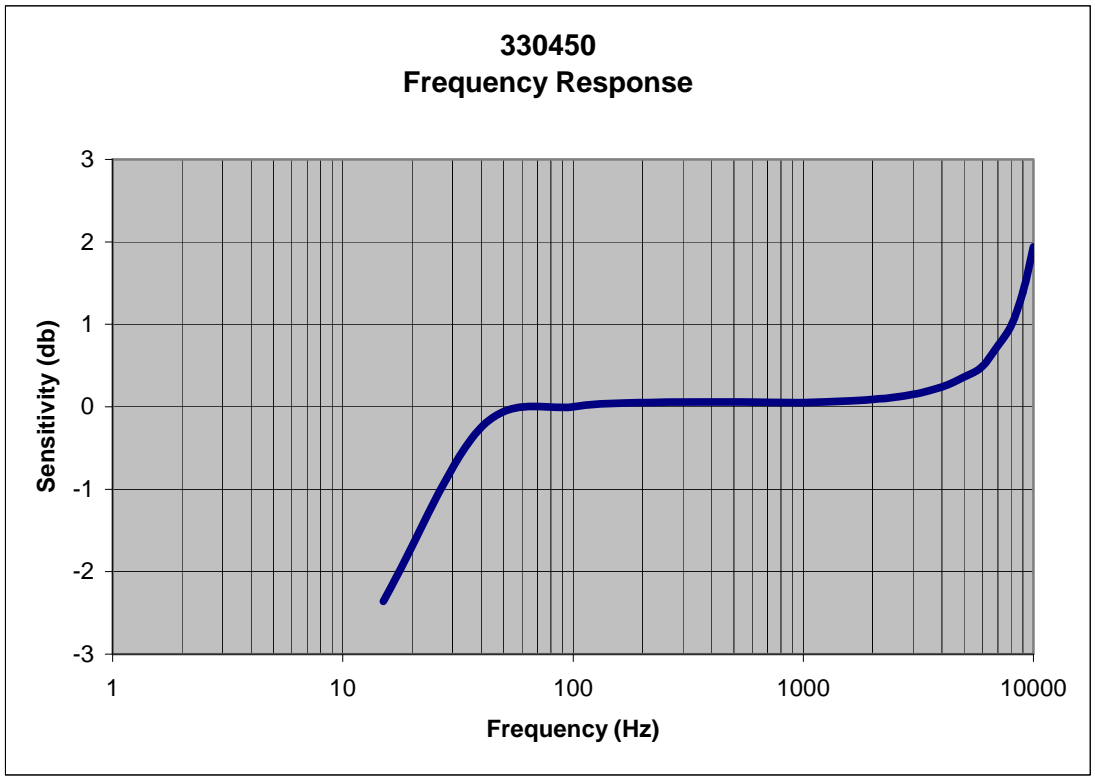

Figure 2: Acceleration Amplitude

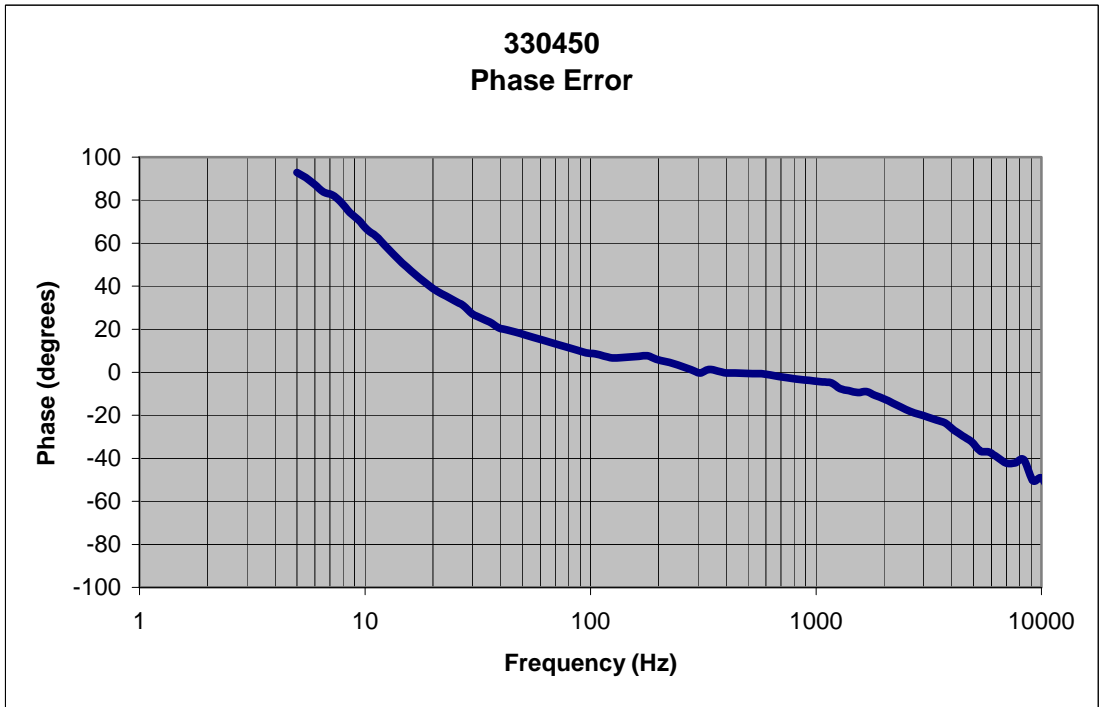
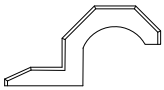
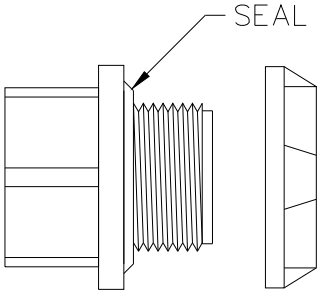
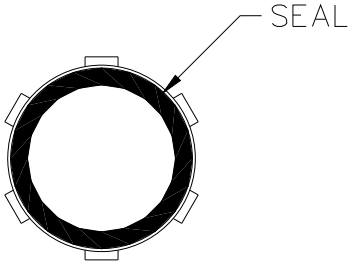
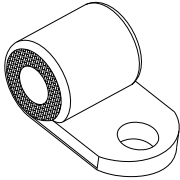

Figure 3: Acceleration Phase Error

**Table 1: Interconnection Cables and Accessories**

APPLICATION	PART NUMBER	DESCRIPTION
*Note: AA - Specifies the length (in feet) of cable required		
Standard Interconnect Cable	16925-AA*	3-conductor shielded 22 AWG (0.5 mm <sup>2</sup> ) cable with 3-socket plug at one end, terminal lugs at the other end. Minimum length of 2.0 ft (0.6 m), maximum length of 99 ft (30 m). See Figure 4
Standard Armored Interconnect Cable	16710-AA*	3-conductor shielded 22 AWG (0.5 mm <sup>2</sup> ) armored cable with 3-socket plug at one end, terminal lugs at the other end. Minimum length of 3.0 ft (0.9 m), maximum length of 99 ft (30 m). See Figure 5
Interconnect Cable with Boot	130539-AA*	3-conductor shielded 18 AWG (1.0 mm <sup>2</sup> ) cable with 3-socket plug and fluorosilicone elastomer boot at one end, terminal lugs at the other end. Minimum length of 2.0 ft (0.6 m), maximum length of 99 ft (30 m). A manual is available to assist with installation of this cable (part number 133080-01). See Figure 6
330450 Manual	139976-01	User Guide
Spare Mating Connector	00531080	Mating connector for 330450 HTAS.
Electronics Housing Strap	03818073	<p>1 inch rigid conduit strap for securing the electronics housing.</p> 

<p>Electronics Mounting Hub</p>	<p>03818071</p>	<p>1 inch weather tight hub used to mount the electronics housing in a weatherproof enclosure.</p>  <p>The diagram shows a cross-section of the hub on the left, featuring a central opening and a spring seal. An arrow labeled 'SEAL' points to the spring. To the right is a side view of the hub, showing its cylindrical shape and a flange at the top.</p>
<p>Seal Ring</p>	<p>03818072</p>	<p>1 inch sealing lock ring used to mount the electronics housing. Two rings are required to mount the electronics.</p>  <p>The diagram shows a top-down view of a circular seal ring. It has four locking tabs around its perimeter and a central seal. An arrow labeled 'SEAL' points to the central seal.</p>
<p>Cable Clamp</p>	<p>169546</p>	<p>Stainless steel mesh tie down clamp for the hardline cable. For temperatures greater than 260C (500F).</p>  <p>The diagram shows a perspective view of a cylindrical mesh clamp. It has a locking tab on one side and a circular opening on the other.</p>

PART NUMBER 16925 -   (SEE NOTE)

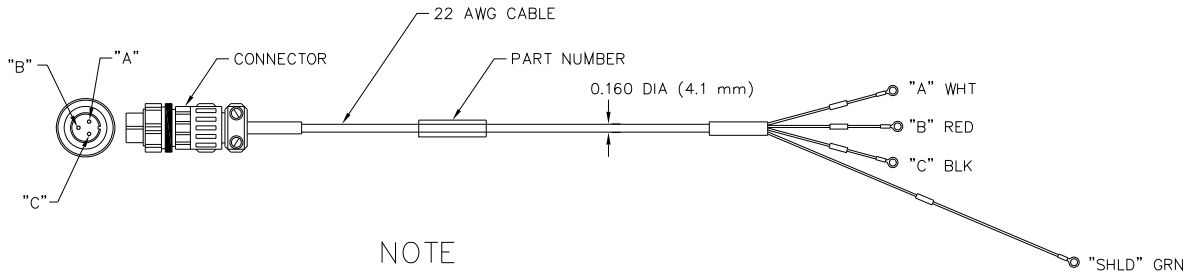

NOTE

INCREMENTS OF 1.0 FOOT (0.30 Metres)
EXAMPLE: <input type="text"/> <input type="text"/> = 2 FEET (0.61 Metres)
<input type="text"/> <input type="text"/> = 25 FEET (7.62 Metres)
MIN LENGTH = 2.0 FEET (0.61 Metres)
MAX LENGTH = 99 FEET (30.18 Metres)

\*ALL DIMENSION ARE IN INCHES (MILLIMETRES) UNLESS OTHERWISE SPECIFIED.

Figure 4: Standard Interconnect Cable

PART NUMBER 16710 -   (SEE NOTE)

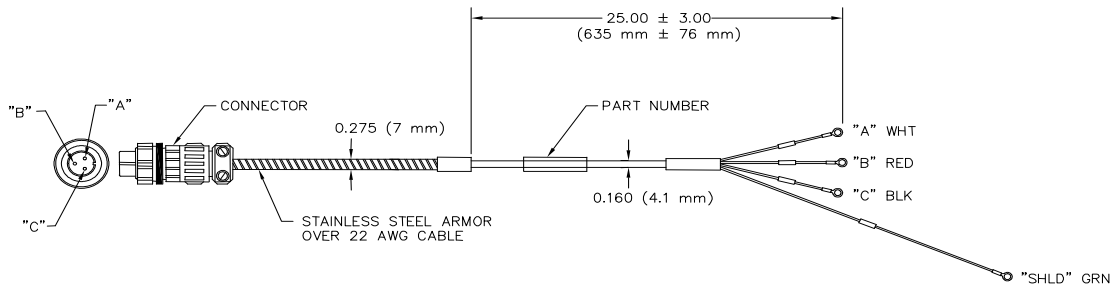

NOTE

INCREMENTS OF 1.0 FOOT (0.30 Metres)
EXAMPLE: <input type="text"/> <input type="text"/> = 3 FEET (0.91 Metres)
<input type="text"/> <input type="text"/> = 25 FEET (7.62 Metres)
MIN LENGTH = 3.0 FEET (0.91 Metres)
MAX LENGTH = 99 FEET (21.34 Metres)

\*ALL DIMENSIONS ARE IN INCHES (MILLIMETRES) UNLESS OTHERWISE SPECIFIED.

Figure 5: Standard Armored Interconnect Cable

PART NUMBER 130539 –  (SEE NOTE)

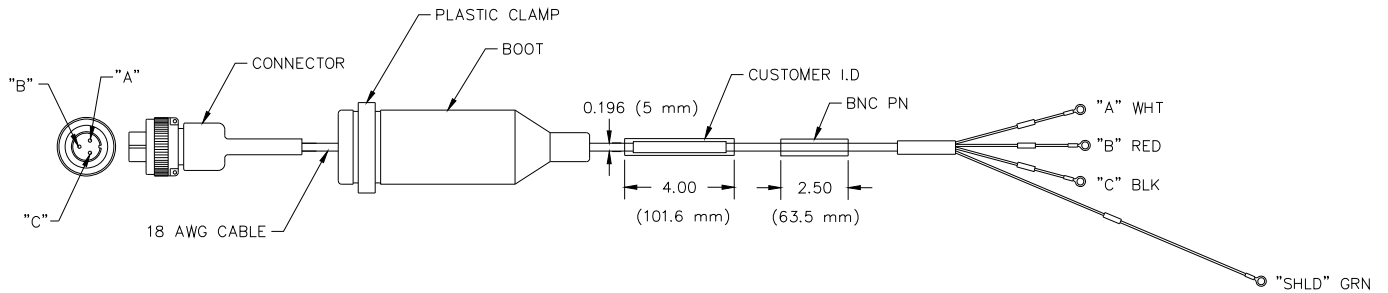

NOTE

INCREMENTS OF 1.0 FOOT (0.30 Metres)
EXAMPLE: <span style="border: 1px solid black; padding: 2px;">12</span> = 12 FEET (3.66 Metres)
<span style="border: 1px solid black; padding: 2px;">25</span> = 25 FEET (7.62 Metres)
MIN LENGTH = 2.0 FEET (0.61 Metres)
MAX LENGTH = 99 FEET (30.18 Metres)

\*ALL DIMENSIONS ARE IN INCHES (MILLIMETRES) UNLESS OTHERWISE SPECIFIED

**Figure 6: Standard Right Angle Interconnect Cable**

\* denotes trademarks of Bently Nevada, LLC, a wholly owned subsidiary of General Electric Company.

© 2005 – 2009 Bently Nevada LLC. All rights reserved.

1631 Bently Parkway South, Minden, Nevada USA 89423

Phone: 775.782.3611 Fax: 775.215.2873

[www.ge-energy.com/bently](http://www.ge-energy.com/bently)

# 330400 and 330425 Accelerometer Acceleration Transducers

Bently Nevada\* Asset Condition Monitoring

---



## Description

These accelerometers are intended for critical machinery applications where casing acceleration measurements are required, such as gear mesh monitoring. The 330400 is designed to address the requirements of American Petroleum Institute Standard 670 for accelerometers. It provides an amplitude range of 50 g peak and a sensitivity of 100 mV/g. The 330425 is identical except it provides a larger amplitude range (75 g peak) and a sensitivity of 25 mV/g.

### **Caution**

If housing measurements are being made for overall protection of the machine, thought should be given to the usefulness of the measurement for each application. Most common machine malfunctions (imbalance, misalignment, etc.) originate at the rotor and cause an increase (or at least a change) in rotor vibration. In order for any housing measurement alone to be effective for overall machine protection, a significant amount of rotor vibration must be faithfully transmitted to the bearing housing or machine casing, or more specifically, to the mounting location of the transducer.

In addition, care should be exercised in the physical installation of the transducer. Improper installation can result in a degradation of the transducer's performance, and/or the generation of signals which do not represent actual machine vibration. Integration of the output to velocity can worsen this. Extreme caution should be exercised if integrating to velocity. For high quality velocity measurements the 330500 Velomitor\* Sensor should be used.

Upon request, we can provide engineering services to determine the appropriateness of housing measurements for the machine in question and/or to provide installation assistance.



---

## Specifications

Parameters are specified from +20 to +30 °C (+68 to +86 °F) and 100 Hz unless otherwise indicated.

**Note:** Operation outside the specified limits may result in false readings or loss of machine monitoring.

---

### Electrical

#### 330400

**Sensitivity:**

10.2 mV/m/s<sup>2</sup> (100 mV/g) ±5%.

**Acceleration range:**

490 m/s<sup>2</sup> (50 g) peak overall acceleration within the 10 Hz to 15 kHz frequency span. Vibration at frequencies above 15 kHz, especially at the transducers resonance will significantly decrease this range.

**Amplitude Linearity:**

±1% to 490 m/s<sup>2</sup> (50 g) peak.

**Broadband Noise Floor (10 Hz to 15 kHz):**

0.039 m/s<sup>2</sup> (0.004 g) rms.

---

#### 330425

**Sensitivity:**

2.5 mV/m/s<sup>2</sup> (25 mV/g) ±5%.

**Acceleration Range:**

735 m/s<sup>2</sup> (75 g) peak overall acceleration within the 10 Hz to 15 kHz frequency span. Vibration at frequencies above 15 kHz, especially at the transducer's resonance, will significantly decrease this range.

**Amplitude Linearity:**

±1% to 735 m/s<sup>2</sup> (75 g) peak.

**Broadband Noise Floor (10 Hz to 15 kHz):**

0.098 m/s<sup>2</sup> (0.01 g) rms.

---

### Both Units

**Frequency Response:**

10 Hz to 15 kHz  
(600 cpm to 900,000 cpm) ±3dB;  
30 Hz to 10 kHz  
(1800 cpm to 600,000 cpm) ±10%

**Temperature Sensitivity:**

-11% to +3% typical over the operating temperature range.

**Transverse Sensitivity:**

Less than 5% of axial.

**Mounted Resonant Frequency:**

Greater than 30 kHz.

**Amplitude of Resonant Peak:**

20 dB maximum.

**Base Strain Sensitivity:**

*For serial numbers*

*preceded by the letter "G" (including all new sensors):*

49 mm/s<sup>2</sup>/μstrain (0.005 g/μstrain)

*For serial numbers*

*NOT preceded by the letter "G" (shipped prior to April 2004):*

980 mm/s<sup>2</sup>/μstrain (0.100 g/μstrain) without Mounting Base (API adapter);

---

Specifications and Ordering Information  
Part Number 141638-01  
Rev. K (09/09)

4.9 mm/s<sup>2</sup>/μstrain (0.0005 g/μstrain) with Mounting Base (API adapter) supplied with the accelerometer.

**Note:** Bently Nevada recommends installing with the Mounting base to minimize base strain sensitivity for serial numbers NOT preceded by the letter "G".

LCIE 04ATEX6042X  
T4 @ -40°C ≤ Ta ≤ 100°C



II 3 G  
EEx nL IIC T4  
LCIE 04ATEX6041X  
T4 @ -40°C ≤ Ta ≤ 100°C

**Maximum cable length:**

305 metres (1000 ft) with no degradation of signal.

**Power requirements:**

**Input Voltage**

-24 ± 0.5 Vdc.

**Bias Current:**

2 mA nominal.

**Output Bias Voltage:**

-8.5 ± 0.5 Vdc.

**Grounding:**

Case isolated.

---

**Hazardous Area Approvals**

Multiple approvals for hazardous areas certified by Canadian Standards Association (CSA) in North America and by LCIE in Europe.

**North America**

Ex ia IIC T4  
AEx ia IIC T4  
Class I, Div 1 Groups A, B, C & D  
When installed per dwg 167538  
T4 @ -40°C ≤ Ta ≤ 100°C

Ex nL IIC T4  
AEx nL IIC T4  
Class I, Div 2 Groups A, B, C & D  
When installed per dwg 167538  
T4 @ -40°C ≤ Ta ≤ 100°C

**European/ATEX**



II 1 G  
EEx ia IIC T4

**IECEx**

Ex ia IIC T4  
IEC Ex LCI 06.0003X  
Ex nL IIC T4  
IEC Ex LCI 06.0002X  
T4 @ -40°C ≤ Ta ≤ 100°C

**Brazil**

BR-Ex ia IIC T4  
MC, AEX-8101-X  
T4 @ -40°C ≤ Ta ≤ 100°C

---

**Compliance and Certification**

**American Bureau of Shipping (ABS) Type approval**

Certification Number:  
09-HS446965A-PDA

---

**Electromagnetic Compatibility**

**Electrostatic discharge:**

EN 61000-4-2 (1999), Criteria B.

**Electrical fast transients:**

EN 61000-4-4 (1999), Criteria B.

**Radiated Susceptibility:**

EN 61000-4-3, Criteria A.

**Conducted Susceptibility:**

EN 61000-4-6, Criteria A.

**Surge Capability:**

EN 61000-4-5, Criteria B.

**Magnetic Field:**

EN 61000-4-8, Criteria A.

---

**Environmental Limits**

**Operating and storage temperature:**

-55°C to +121°C (-67°F to +250°F)

**Shock Survivability:**

49,050 m/s<sup>2</sup> (5000 g) peak, maximum.

**Relative humidity:**

100% condensing, non-submerged. Case is hermetically sealed.

**Magnetic Field Susceptibility:**

<2.21 mm/s<sup>2</sup>/gauss (225 µg/gauss) [50 gauss, 50-60Hz].

---

**Physical**

**Weight (no cable):**

99 g (3.5 oz), typical

**Diameter:**

23 mm (0.93 in).

**Height:**

59 mm (2.3 in), including mounting stud.

**Connector:**

3-pin MIL-C-5015 Receptacle

**Mounting Surface:**

32 µinch rms.

**Mounting torque:**

4.1 N•m (3.0 ft•lb).

**Case material:**

304L stainless steel

**Weight (no cable):**

100 g (3.5 oz), typical

**Mounting angle:**

Any orientation

---

**Ordering Information**

**330400 Accelerometer**

**330400-AA-BB**

---

**330425 Accelerometer**

**330425-AA-BB**

**A: Mounting Thread Option**

**01** ¼-28 UNF integral stud

**02** M8 X 1 integral stud

**B: Agency Approval Option**

**00** None

**05** Multiple approvals (CSA, ATEX, Brazil)

---

**Interconnect Cables**

**Part Number-AA**

**A: Cable Length Option in feet**

For the cables listed below, order in increments of 1.0 ft (305 mm).

**Examples:**

**15** = 15 ft (4.57 m)

**20** = 20 ft (6.10 m)

**130539**

3-conductor shielded 18 AWG (1.0 mm<sup>2</sup>) cable with 3-socket plug and fluorosilicone elastomer boot at one end, terminal lugs at the other end. Minimum length of 2.0 ft (0.6 m), maximum length of 99 ft (30 m). A manual is available to assist with installation of this cable (part number 133080-01).

**16925**

3-conductor shielded 22 AWG (0.5 mm<sup>2</sup>) cable with 3-socket plug at one end, terminal lugs at the other end. Minimum length of 2.0

ft (0.6 m), maximum length of 99 ft (30 m).

**37439-01**

**For use with serial numbers NOT preceded with the letter "G".**

Mounting Base, ¼-28 to ¼-28.  
Reduces base strain sensitivity.

**16710**

3-conductor shielded 22 AWG (0.5 mm<sup>2</sup>) armored cable with 3-socket plug at one end, terminal lugs at the other end. Minimum length of 3.0 ft (0.9 m), maximum length of 99 ft (30 m).

**37439-02**

**For use with serial numbers NOT preceded with the letter "G".**

Mounting Base, M8X1 to M8X1.  
Reduces base strain sensitivity.

---

## Accessories

**127088-01**

330400 and 330425  
Accelerometer Operations  
Manual.

**43217**

Accelerometer Mounting Kit used with extension part number 108576-01 and O-ring part number 04290422 to allow room for the 330400 or 330425 accelerometer.

**00531080**

Mating connector for 330400 and 330425 Accelerometers.

(See separate datasheet, p/n 141630-01.)

Graphs and Figures

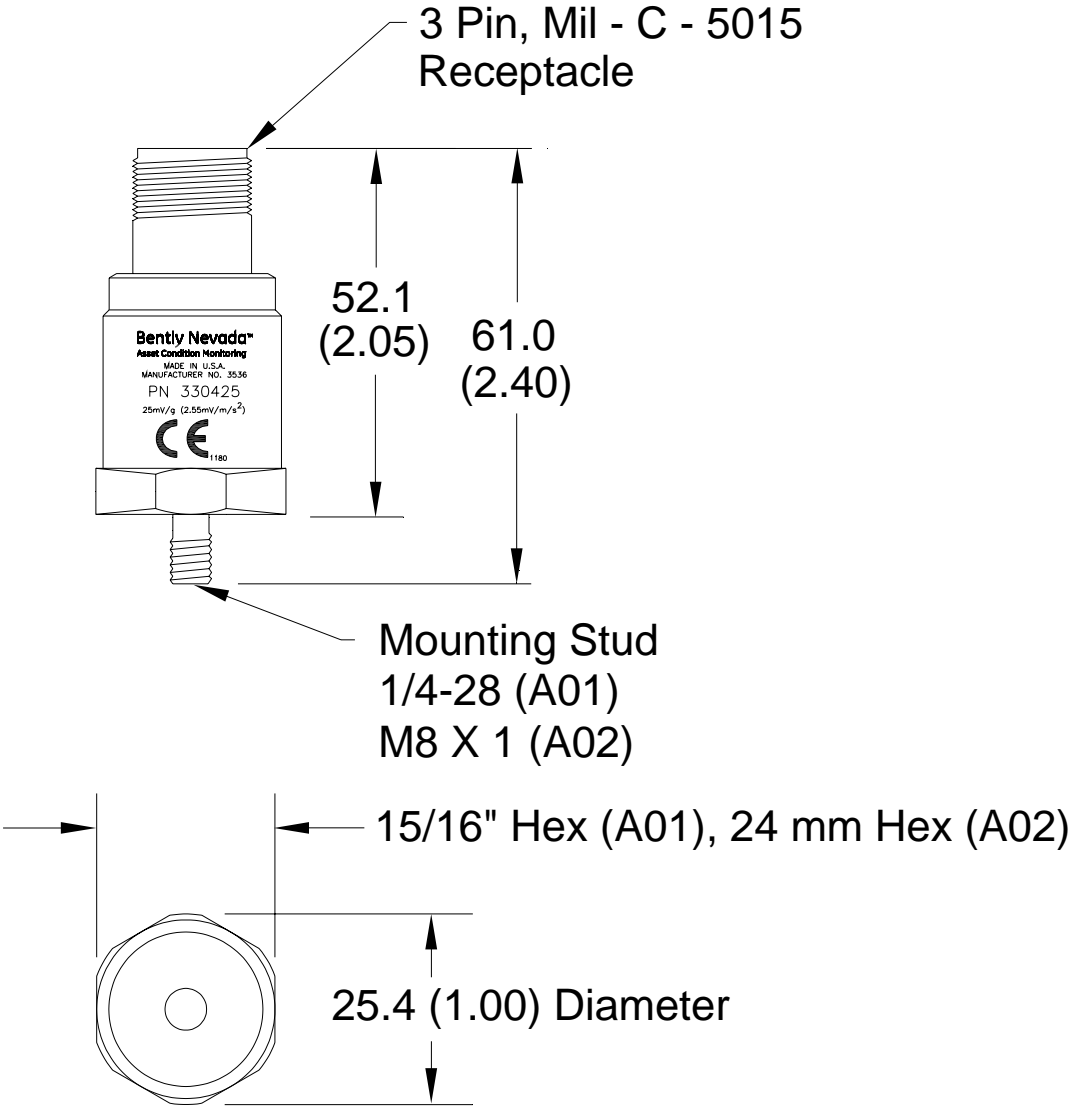

Figure 1: Acceleration Transducer dimensional drawing  
Dimensions are in millimetres (inches)

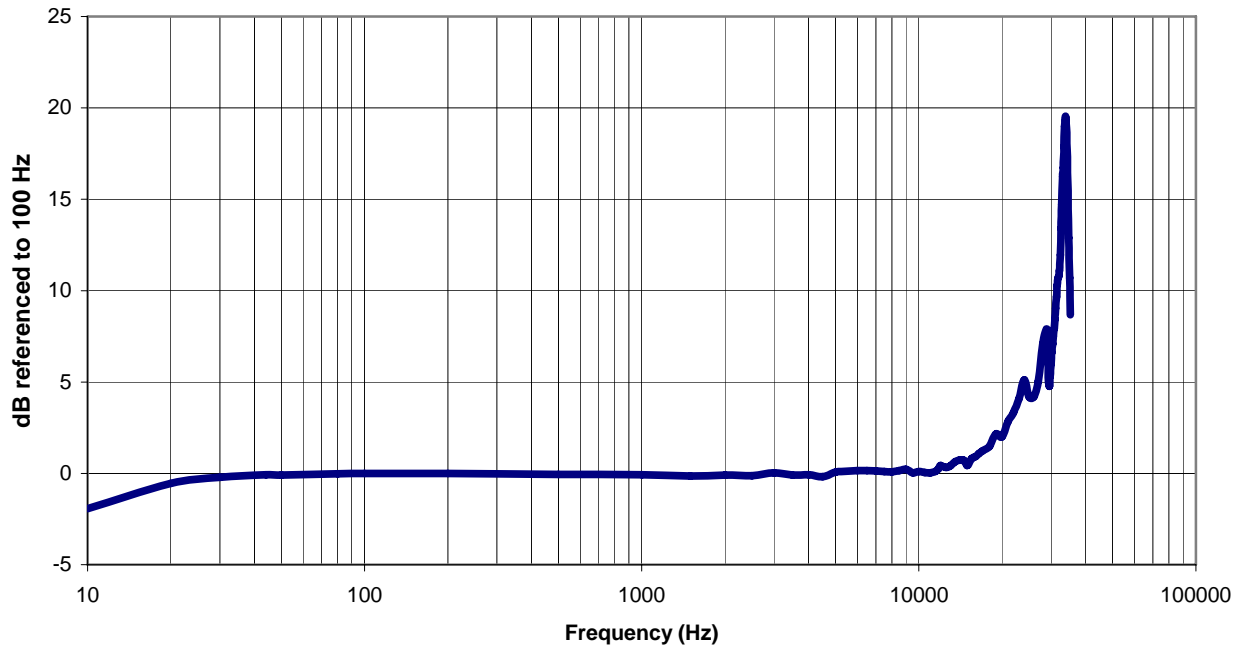

Figure 2: Typical Amplitude Response

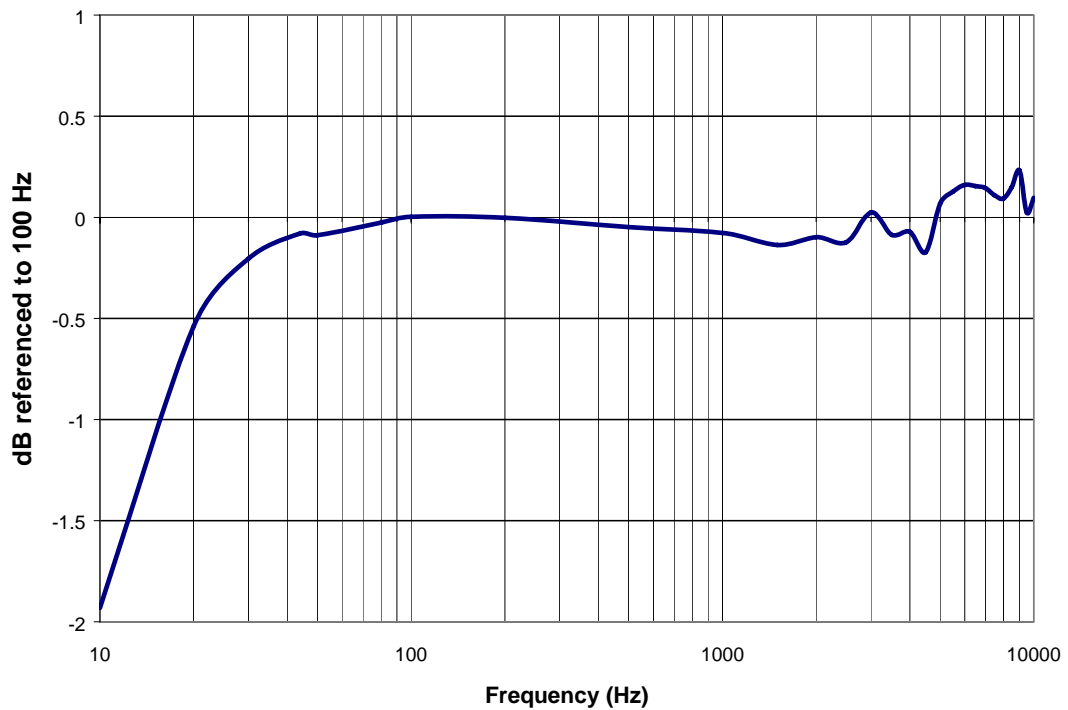

Figure 3: 10 - 10,000 Hz Typical Amplitude Response Detail

\* Denotes trademarks of Bently Nevada, LLC, a wholly owned subsidiary of General Electric Company.

©1999-2009. Bently Nevada LLC. All rights reserved.

1631 Bently Parkway South, Minden, Nevada USA 89423

Phone: 775.782.3611 Fax: 775.215.2873

[www.ge-energy.com/bently](http://www.ge-energy.com/bently)

# 3300 XL 8mm Proximity Transducer System

## Bently Nevada\* Asset Condition Monitoring

---

### Description

The 3300 XL 8 mm Proximity Transducer System consists of:

- One 3300 XL 8 mm probe,
- One 3300 XL extension cable<sup>1</sup>, and
- One 3300 XL Proximitor\* Sensor<sup>2</sup>.

The system provides an output voltage that is directly proportional to the distance between the probe tip and the observed conductive surface and can measure both static (position) and dynamic (vibration) values. The system's primary applications are vibration and position measurements on fluid-film bearing machines, as well as Keyphasor\* reference and speed measurements<sup>3</sup>.

The 3300 XL 8 mm system delivers the most advanced performance in our eddy current proximity transducer systems. The standard 3300 XL 8 mm 5-metre system also fully complies with the American Petroleum Institute's (API) 670 Standard (4<sup>th</sup> Edition) for mechanical configuration, linear range, accuracy, and temperature stability. All 3300 XL 8 mm proximity transducer systems provide this level of performance and support complete interchangeability of probes, extension cables, and Proximitor sensors, eliminating the need to match or bench calibrate individual components

Each 3300 XL 8 mm Transducer System component is backward-compatible and interchangeable<sup>4</sup> with other non-XL 3300 series 5 mm and 8 mm transducer system components<sup>5</sup>. This compatibility includes the 3300 5 mm probe, for applications in which an 8 mm probe is too large for the available mounting space<sup>6,7</sup>.

### Proximitor Sensor

The 3300 XL Proximitor Sensor incorporates numerous improvements over previous designs. Its physical packaging allows you to use it in high-density DIN-rail installations. You can also mount the sensor in a traditional panel mount configuration, where it shares an identical 4-hole mounting "footprint" with older Proximitor Sensor designs. The mounting base for either option provides electrical isolation and eliminates the need for separate isolator plates. The 3300 XL Proximitor Sensor is highly immune to radio frequency interference, allowing you to install it in fiberglass housings without adverse effects from nearby radio frequency signals. The 3300 XL Proximitor Sensor's improved RFI/EMI immunity satisfies European CE mark approvals without requiring special shielded conduit or metallic housings, resulting in lower installation costs and complexity.

The 3300 XL's SpringLoc terminal strips require no special installation tools and facilitate faster, more robust field wiring connections by eliminating screw-type clamping mechanisms that can loosen.



imagination at work

---

Specifications and Ordering Information  
Part Number 141194-01  
Rev. R (07/12)

## Proximity Probe and Extension Cable

The 3300 XL probe and extension cable also reflect improvements over previous designs. A patented TipLoc\* molding method provides a more robust bond between the probe tip and the probe body. The probe's cable incorporates a patented CableLoc\* design that provides 330 N (75 lbf) pull strength to more securely attach the probe cable and probe tip.

You can also order 3300 XL 8 mm probes and extension cables with an optional FluidLoc\* cable option. This option prevents oil and other liquids from leaking out of the machine through the cable's interior.

## Connectors

The 3300 XL probe, extension cable, and Proximitor sensor have corrosion-resistant, gold-plated ClickLoc\* connectors. These connectors require only finger-tight torque (the connectors will "click" when tight), and the specially-engineered locking mechanism prevents the connectors from loosening. These connectors require no special tools for installation or removal.

You can order the 3300 XL 8 mm probes and extension cables with connector protectors already installed. We can also supply connector protectors separately for field installations (such as when an application must run the cable through restrictive conduit). We recommend connector protectors for all installations to provide increased environmental protection<sup>8</sup>.

## Extended Temperature Range Applications

An extended temperature range (ETR) probe and ETR extension cable are available for applications in which either the probe lead or extension cable may exceed the standard 177 °C (350 °F) temperature specification. The ETR probe has an extended temperature rating for up to 218 °C (425 °F). The ETR extension cable rating is up to 260 °C (500 °F). Both the ETR probe and cable are compatible with standard temperature probes and cables, for example, you can utilize an ETR probe with the 330130 extension cable. The ETR system uses the standard 3300 XL Proximitor Sensor. Note that when you use any ETR component as part of your system, the ETR component limits the system accuracy to the accuracy of the ETR system.

## Description Notes:

- 1-metre systems do not use an extension cable.
- Proximitor sensors are supplied by default from the factory calibrated to AISI 4140 steel. Calibration to other target materials is available upon request.
- Consult Bently Nevada\* Applications Note, *Considerations when using Eddy Current Proximity Probes for Overspeed Protection Applications*, when considering this transducer system for tachometer or overspeed measurements.
- 3300 XL 8 mm components are both electrically and physically interchangeable with non-XL 3300 5 mm and 8 mm components. Although the packaging of the 3300 XL Proximitor Sensor differs from its predecessor, its design fits in the same 4-hole mounting pattern when used with the 4-hole mounting base, and will fit within the same mounting space specifications (when minimum permissible cable bend radius is observed).
- Mixing XL and non-XL 3300-series 5 mm and 8 mm system components limits system performance to the specifications for the non-XL 3300 5 mm and 8 mm Transducer System.
- The 3300-series 5 mm probe (refer to Specifications and Ordering Information p/n 141605-01) uses smaller physical packaging, but does not reduce the side view clearances or tip-to-tip spacing requirements as compared to an 8 mm probe. It is used when physical (not electrical) constraints preclude the use of an 8 mm probe. When your application requires narrow side view probes, use the 3300 NSv\* Proximity Transducer System (refer to Specifications and Ordering Information p/n 147385-01).
- 8 mm probes provide a thicker encapsulation of the probe coil in the molded PPS plastic probe tip. This results in a more rugged probe. The larger diameter of the probe body also provides a stronger, more robust case. We recommend that you use 8 mm probes when possible to provide optimal robustness against physical abuse.
- Each 3300 XL extension cable includes silicone tape that you can use instead of connector protectors. We do not recommend silicone tape for applications that will expose the probe-to-extension cable connection to turbine oil.

## Specifications

Unless otherwise noted, the following specifications are for a 3300 XL 8 mm Proximitor Sensor, extension cable and 8 mm probe between +18 °C and +27 °C (+64 °F to +80 °F), with a -24 Vdc power supply, a 10 kΩ load, an AISI 4140 steel target, and a probe gapped at 1.27 mm (50 mils). Performance characteristics apply to systems that consist solely of 3300 XL 8 mm components. The system accuracy and interchangeability specifications do not apply to transducer systems that are calibrated to any target other than our AISI 4140 steel target.

### Electrical

#### Proximitor Sensor Input

Accepts one non-contacting 3300-series 5 mm, 3300 8 mm **or** 3300 XL 8 mm Proximity Probe and Extension Cable.

#### Power

Requires -17.5 Vdc to -26 Vdc without barriers at 12 mA maximum consumption, -23 Vdc to -26 Vdc with barriers. Operation at a more positive voltage than -23.5 Vdc can result in reduced linear range.

#### Supply Sensitivity

Less than 2 mV change in output voltage per volt change in input voltage.

#### Output Resistance

50 Ω

#### Nominal Probe DC Resistance

Resistance ( $R_{\text{PROBE}}$ ) from Center Conductor to Outer Conductor

Probe Length	$R_{\text{PROBE}}$ (Ω)
0.5	7.45 ± 0.50
1.0	7.59 ± 0.50
1.5	7.73 ± 0.50
2.0	7.88 ± 0.50
5.0	8.73 ± 0.70
9.0	9.87 ± 0.90

#### Nominal Extension Cable DC Resistance

Resistance ( $R_{\text{CORE}}$ ) from Center Conductor to Center Conductor

Length of Extension Cable (m)	$R_{\text{CORE}}$ (Ω)
3.0	0.66 ± 0.10
3.5	0.77 ± 0.12
4.0	0.88 ± 0.13
4.5	0.99 ± 0.15
7.0	1.54 ± 0.23
7.5	1.65 ± 0.25
8.0	1.76 ± 0.26
8.5	1.87 ± 0.28

Resistance ( $R_{\text{JACKET}}$ ) from Outer Conductor to Outer Conductor

Length of Extension Cable (m)	$R_{\text{JACKET}}$ (Ω)
3.0	0.20 ± 0.04
3.5	0.23 ± 0.05
4.0	0.26 ± 0.05
4.5	0.30 ± 0.06
7.0	0.46 ± 0.09
7.5	0.49 ± 0.10
8.0	0.53 ± 0.11
8.5	0.56 ± 0.11

#### Extension Cable Capacitance

69.9 pF/m (21.3 pF/ft) typical

#### Field Wiring

0.2 to 1.5 mm<sup>2</sup> (16 to 24 AWG) . Recommend using 3-conductor shielded triad cable and tinned field wiring. Maximum length of 305 metres (1,000 feet) between the 3300 XL Proximitor Sensor and the monitor. See the frequency response graphs in through Figure 13 (pages 28 and 29) for signal rolloff at high frequencies when using longer field wiring lengths.

## Linear Range

2 mm (80 mils). Linear range begins at approximately 0.25 mm (10 mils) from target and is from 0.25 to 2.3 mm (10 to 90 mils) (approximately -1 to -17 Vdc).

## Recommended Gap Setting for Radial Vibration

-9Vdc [approximately 1.27 mm (50 mils)]

## Incremental Scale Factor (ISF)

*Standard  
5- or 1- metre  
System:*

7.87 V/mm (200 mV/mil)  $\pm$  5% including interchangeability error when measured in increments of 0.25 mm (10 mils) over the 80 mil linear range from 0 °C to +45 °C (+32 °F to +113 °F).

*Standard  
9-metre  
System:*

7.87 V/mm (200 mV/mil)  $\pm$  6.5% including interchangeability error when measured in increments of 0.25 mm (10 mils) over the 80 mil linear range from 0 °C to +45 °C (+32 °F to +113 °F).

*Extended  
Temperature  
Range (ETR)  
for 5- and  
9-Metre  
Systems:*

7.87 V/mm (200 mV/mil)  $\pm$  6.5% including interchangeability error when measured in increments of 0.25 mm (10 mils) over the 80 mil linear range from 0 °C to +45 °C (+32 °F to +113 °F).

## Deviation from best fit straight line (DSL)

*Standard  
5- or 1-metre  
System:*

Less than  $\pm 0.025$  mm ( $\pm 1$  mil) with components at 0 °C to +45 °C (+32 °F to +113 °F).

*Standard  
9-metre  
System:*

Less than  $\pm 0.038$  mm ( $\pm 1.5$  mil) with components at 0 °C to +45 °C (+32 °F to +113 °F).

*Extended  
Temperature  
Range 5 and  
9-metre  
Systems:*

Less than  $\pm 0.038$  mm ( $\pm 1.5$  mil) with components at 0 °C to +45 °C (+32 °F to +113 °F).

## Performance Over Extended Temperatures

*Standard  
5- or 1-metre  
System:*

Over a probe temperature range of -35 °C to +120 °C (-31 °F to +248 °F) with the Proximitor sensor and extension cable between 0 °C to +45 °C (+32 °F to +113 °F), the ISF remains within  $\pm 10\%$  of 7.87 V/mm (200 mV/mil) and the DSL remains within  $\pm 0.076$  mm ( $\pm 3$  mils).

Over a Proximitor sensor and extension cable temperature range of -35 °C to +65 °C (-31 °F to +149 °F) with the probe between 0 °C to +45 °C (+32 °F to +113 °F), the ISF remains within  $\pm 10\%$  of 7.87 V/mm (200 mV/mil) and the DSL remains within  $\pm 0.076$  mm ( $\pm 3$  mils).

*Standard  
9-metre  
System:*

Over a probe temperature range of -35 °C to +120 °C (-31 °F to +248 °F) with the Proximitor sensor and extension cable between 0 °C to +45°C (+32 °F to +113 °F), the ISF remains within ±18% of 7.87 V/mm (200 mV/mil) and the DSL remains within ±0.152 mm (±6 mils).

Over a Proximitor sensor and extension cable temperature range of -35 °C to +65 °C (-31 °F to +149 °F) with the probe between 0 °C to +45 °C (+32 °F to +113 °F), the ISF remains within ±18% of 7.87 V/mm (200 mV/mil) and the DSL remains within ±0.152 mm (±6 mils).

*Extended  
Temperature  
Range 5 and  
9-metre  
Systems:*

Over a probe and extension cable temperature range of -35 °C to +260 °C (-31 °F to +500 °F) with the Proximitor sensor between 0 °C to +45 °C (+32 °F to +113 °F), the ISF remains within ±18% of 7.87 V/mm (200 mV/mil) and the DSL remains within ±0.152 mm (±6 mils).

**Frequency  
Response**

(0 to 10 kHz), +0, -3 dB, with up to 305 metres (1000 feet) of field wiring.

**Minimum  
Target Size**

15.2 mm (0.6 in) diameter (flat target)

**Shaft Diameter**

*Minimum:*

50.8 mm (2 in)

*Recommended  
Minimum:*

76.2 mm (3 in)

When gapped at the center of the linear range, the interaction between two separate transducer systems (cross-talk) will be less than 50 mV on shaft diameters of at least 50 mm (2 in) or greater. You should take care to maintain minimum separation of transducer tips, generally at least 40 mm (1.6 in) for axial position measurements or 38 mm (1.5 in) for radial vibration measurements to limit cross-talk to 50 mV or less. Radial vibration or position measurements on shaft diameters smaller than 76.2 mm (3 in) will generally change the scale factor.

**Effects of 60 Hz  
Magnetic Fields  
up to 300 Gauss**

Output Voltage in Mil pp/Gauss

Gap (mil)	5- or 1-metre Proximitor Sensor	9-metre Proximitor Sensor	Probe	Ext. Cable
10	0.0119	0.0247	0.0004	0.0004
50	0.0131	0.0323	0.0014	0.0014
90	0.0133	0.0348	0.0045	0.0045

**Compliance and Certifications**

**EMC**

European Community Directives:  
EMC Directive 2004/108/EC  
Standards:  
EN61000-6-2  
EN61000-6-4

**Maritime**

ABS 2009 Steel Vessels Rules  
1-1-4/7.7, 4-8-3/1.11.1, 4-9-7/13

## Hazardous Area Approvals

**Note:** Multiple approvals for hazardous areas certified by Canadian Standards Association (C/US) in North America and by Baseefa for Europe and IEC Ex.

### Field Wiring Limitations:

Type Approval:	Gas Group	Capacitance (μF)	Inductance (mH)	L/R Ratio (μH/Ω)
ATEX and IEC Zone 0/1	IIC	0.078	0.99	29.2
	IIB	0.645	7.41	117.0
	IIA	2.144	15.6	234.0
CSA Div 1	A & B	0.070	1.0	29.2
	C	0.600	5.0	117.0
	D	2.09	11.0	234.0
	All	0.460	100.0	N/A

### North America

3300 XL  
Proximitor  
Sensor and  
probe, ia:

Ex ia IIC T4/T5; Class I Zone 0 or Class 1; Groups A, B, C, and D, Class II, Groups E, F and G, Class III when installed with intrinsically safe zener barriers per drawing 141092 or when installed with galvanic isolators.

3300 XL  
Proximitor  
Sensor and  
probe, nA:

Ex nA IIC T4/T5 Class I Zone 2 or Class I, Division 2, Groups A, B, C, and D, when installed without barriers per drawing 140979.  
T5 @ Ta = -35 °C to +85 °C.  
T4 @ Ta = -51 °C to +100 °C.

### Europe

3300 XL  
Proximitor  
Sensor, ia:

 II 1 G EEx ia IIC T4/T5 when installed per drawing 141092.

3300 XL  
Proximitor  
Sensor, nA:

 II 3 G Ex nA II T4/T5 when installed per drawing 140979.  
T5 @ Ta = -35 °C to +85 °C  
T4 @ Ta = -51 °C to +100 °C

3300 XL  
8mm probe,  
ia:

II 1 G EEx ia IIC, Temperature Classification per Table 1 when installed per drawing 142491.

3300 XL  
8mm probe,  
nA:

II 3 G EEx nA II, Temperature Classification per Table 1 when installed per drawing 142491.

### Brazil

3300 XL  
Proximitor  
Sensor, ia:

BR-Ex ia IIC T4  
(-51°C ≤ Ta ≤ +100°C)  
BR-Ex ia IIC T5  
(-35°C ≤ Ta ≤ +85°C)

Terminal J1	Terminal J2
Ui = -28V	Uα = -28V
Ii = 140mA	Iα = 140mA
Pi = 0.91W	Pα = 0.91W
Ci = 0 F	Ci = 0 F
Li = 0 H	Li = 0.7 mH

Applicable for Part numbers:  
330180, 330980, 330780, 330850,  
330878.

3300 XL  
8mm and  
3300 5mm  
Eddy Current  
Probes, ia:

BR-Ex ia IIC Temperature  
Classification per Table 1.

Ui = -28V      Ci = 0 F

li = 140 mA    Li = 0 H  
 Pi = 0.91 W

**Hazardous Area  
 Conditions of  
 Safe Use:**

ATEX:

Follow the conditions of safe use included on the Declaration of Conformance sent with each product.

Canadian Standards Association (CSA):

Division 1 (Intrinsically safe): Install per Bently Nevada drawing 141092.

Division 2 (non-Incendive): Install per Bently Nevada drawing 140979.

IECEX:

Zone 0 (Intrinsically safe): The Proximitor Sensor must be installed to minimize the risk of impact or friction with other metallic surfaces.

Zone 2 (non-Incendive): The probe must be supplied from a voltage-limited source.

**IEC Ex**

3300 XL  
 Proximitor  
 Sensor, ia:

Ex ia IIC T4 (-51°C ≤ Ta ≤ +100°C) /  
 T5 (-35°C ≤ Ta ≤ +85°C)

Ui = -28V    Ci = 0  
 li = 140mA    Li = 10µH  
 Pi = 0.84W

3300 XL  
 Proximitor  
 Sensor, nA:

Ex nA II T4 (-51°C ≤ Ta ≤ +100°C) /  
 T5 (-35°C ≤ Ta ≤ +85°C)

Ui = -28V

3300 XL  
 8mm and  
 3300 5mm  
 Eddy Current  
 Probes, ia:

Ex ia IIC Temperature  
 Classification per Table 1.

Ui = -28V    Ci = 1.5 nF  
 li = 140 mA    Li = 200 µH  
 Pi = 0.84 W

3300 XL  
 8mm and  
 3300 5mm  
 Eddy Current  
 Probes, nA:

Ex nA II for Zone 2 Temperature  
 Classification per Table 1.

**Table 1: Probe Temperature Classification**

Temperature Classification	Ambient Temperature (Probe Only)
T1	-51°C to +232°C
T2	-51°C to +177°C
T3	-51°C to +120°C
T4	-51°C to +80°C
T5	-51°C to +40°C

**Mechanical**

**Probe Tip  
 Material**

Polyphenylene sulfide (PPS).

**Probe Case  
 Material**

AISI 303 or 304 stainless steel (SST).

**Probe Cable  
 Specifications**

Standard cable:

75Ω triaxial, fluoroethylene propylene (FEP) insulated probe cable in the following total probe lengths: 0.5, 1, 1.5, 2, 5, or 9 metres.

*Extended Temperature Range cable:*

75Ω triaxial, perfluoroalkoxy (PFA) insulated probe cable in the following total probe lengths: 0.5, 1, 1.5, 2, 5, or 9 metres.

*Armor (optional on both):*

Flexible AISI 302 or 304 SST with FEP outer jacket.

*Tensile Strength (Maximum Rated):*

330 N (75 lbf) probe case to probe lead.

270 N (60 lbf) at probe lead to extension cable connectors.

*Connector Material:*

Gold-plated brass or gold-plated beryllium copper.

*Probe Case Torque:*

Probe Type	Maximum Rated	Recommended
Standard forward-mounted probes	33.9 N•m (300 in•lbf)	11.2 N•m (100 in•lbf)
Standard forward-mount probes - first three threads	22.6 N•m (200 in•lbf)	7.5 N•m (66 in•lbf)
Reverse-mount probes	22.6 N•m (200 in•lbf)	7.5 N•m (66 in•lbf)

**Extension Cable Material**

*Standard cable:*

75Ω triaxial, fluoroethylene propylene (FEP) insulated.

*Extended Temperature Range cable:*

75Ω triaxial, perfluoroalkoxy (PFA) insulated.

*Minimum Cable Bend Radius:*

25.4 mm (1.0 in)

---

**Note:** 3300 XL 8 mm components are both electrically and physically interchangeable with non-XL 3300 5 mm and 8 mm components when minimum permissible cable bend radius is observed..

---

*Connector Material:*

Gold-plated brass or gold-plated beryllium copper.

*Maximum Connector Torque:*

0.565 N•m (5 in•lbf)

*Connector-to-connector recommended torque:*

Connector Type	Tightening Instructions
Two 3300 XL gold "click" type connectors	Finger tight
One non-XL stainless steel connector and one 3300 XL connector	Finger tight plus 1/8 turn using pliers

**Proximator Sensor Material**

A308 aluminum

*Connector Material:*

Gold-plated brass or gold-plated beryllium copper.

**System Length**

5 or 9 metres (including extension cable) or 1 metre (probe only).

**Total System Mass (Typical)**

*Probe:* 0.7 kg (1.5 lbm)

*Extension Cable:* 323 g (11.4 oz)

*Armored Extension Cable:* 34 g/m (0.4 oz/ft)

*Proximitior Sensor:* 103 g/m (1.5 oz/ft)

246 g (8.67 oz)

---

**Note:** Exposing the probe to temperatures below -34 °C (-30 °F) may cause premature failure of the pressure seal.

---

**Probe Pressure**

3300 XL 8 mm probes are designed to seal differential pressure between the probe tip and case. The probe sealing material consists of a Viton® O-ring. Probes are not pressure tested prior to shipment. Contact our custom design department if you require a test of the pressure seal for your application.

---

**Note:** It is the responsibility of the customer or user to ensure that all liquids and gases are contained and safely controlled should leakage occur from a proximity probe. In addition, solutions with high or low pH values may erode the tip assembly of the probe causing media leakage into surrounding areas. Bently Nevada, Inc. will not be held responsible for any damages resulting from leaking 3300 XL 8 mm proximity probes. In addition, 3300 XL 8 mm proximity probes will not be replaced under the service plan due to probe leakage.

---

---

**Environmental Limits**

**Probe Temperature Range**

**Operating and Storage Temperature**

*Standard Probe:* -51 °C to +177 °C (-60 °F to +350 °F)

*Extended Temperature Range Probe:* -51 °C to +218 °C (-60 °F to +425 °F) for the probe tip; -51 °C to +260 °C (-60 °F to +500 °F) for the probe cable and connector.

**Extension Cable Temperature Range**

**Operating and Storage Temperature**

*Standard Cable:* -51 °C to +177 °C (-60 °F to +350 °F)

*Extended Temperature Range Cable:* -51 °C to +260 °C (-60 °F to +500 °F)

**Proximitior Sensor Temperature Range**

**Operating Temperature**

---

Specifications and Ordering Information  
Part Number 141194-01  
Rev. R (07/12)

-51 °C to +100 °C (-60 °F to +212 °F)

**Storage  
Temperature**

-51 °C to +105 °C (-60 °F to +221 °F)

**Relative  
Humidity**

Less than a 3% change in Average Scale Factor (ASF) when tested in 93% humidity in accordance with IEC standard 68-2-3 for up to 56 days.

**Patents:**

Components or procedures described in one or more of the following patents apply to this product: 5,016,343; 5,126,664; 5,351,588; and 5,685,884.

---

## Ordering Information Probes

### 3300 XL 8 mm Proximity Probes:

330101 3300 XL 8 mm Probe, 3/8-24 UNF thread, without armor<sup>2</sup>

330102 3300 XL 8 mm Probe, 3/8-24 UNF thread, with armor<sup>2</sup>

#### Part Number-AXX-BXX-CXX-DXX-EXX

A: Unthreaded Length Option

---

**Note:** Unthreaded length must be at least 0.8 inches less than the case length.

Order in increments of 0.1 in

#### Length configurations:

**Maximum unthreaded length:** 8.8 in

**Minimum unthreaded length:** 0.0 in

**Example: 0 4** = 0.4 in

B: Overall Case Length Option

Order in increments of 0.1 in

#### Threaded length configurations:

**Maximum case length:** 9.6 in

**Minimum case length:** 0.8 in

**Example: 2 4** = 2.4 in

C: Total Length Option

**0 5** 0.5 metre (1.6 feet)

**1 0** 1.0 metre (3.3 feet)

**1 5** 1.5 metre (4.9 feet)

**2 0** 2.0 metres (6.6 feet)

**5 0** 5.0 metres (16.4 feet)

---

**Note:** 5-metre probes are designed for use with the 5-metre Proximitor sensor only.

**9 0** 9.0 metres (29.5 feet)

D: Connector and Cable-Type Option

**0 1** Miniature coaxial ClickLoc connector with connector protector, standard cable

**0 2** Miniature coaxial ClickLoc connector, standard cable

**1 1** Miniature coaxial ClickLoc connector with connector protector, FluidLoc cable

**1 2** Miniature coaxial ClickLoc connector, FluidLoc cable

E: Agency Approval Option

**0 0** Not required

**0 5** Multiple Approvals

---

## 3300 XL 8 mm Proximity Probes, Metric:

330103 3300 XL 8 mm Probe, M10 x 1 thread, without armor<sup>2</sup>

330104 3300 XL 8 mm Probe, M10 x 1 thread, with armor<sup>2</sup>

#### Part Number-AXX-BXX-CXX-DXX-EXX

A: Unthreaded Length Option

---

**Note:** Unthreaded length must be at least 20 mm less than the case length.

Order in increments of 10 mm.

#### Length configuration:

**Maximum unthreaded length:** 230 mm

**Minimum unthreaded length:** 0 mm

**Example: 0 6** = 60 mm

B: Overall Case Length Option

Order in increments of 10 mm.

#### Metric thread configurations:

**Maximum length:** 250 mm

**Minimum length:** 20 mm

**Example: 0 6** = 60 mm

C: Total Length Option

**0 5** 0.5 metre (1.6 feet)

**1 0** 1.0 metre (3.3 feet)

**1 5** 1.5 metres (4.9 feet)

**2 0** 2.0 metres (6.6 feet)

**5 0** 5.0 metres (16.4 feet)

---

**Note:** 5-metre probes are designed for use with the 5-metre Proximitor sensor only.

**9 0** 9.0 metres (29.5 feet)

D: Connector and Cable-Type Option

**0 1** Miniature coaxial ClickLoc connector with connector protector, standard cable

**0 2** Miniature coaxial ClickLoc connector, standard cable

**1 1** Miniature coaxial ClickLoc connector with connector protector, FluidLoc cable

**1 2** Miniature coaxial ClickLoc connector, FluidLoc cable

E: Agency Approval Option

**0 0** Not required

**0 5** Multiple Approvals

---

### 3300 XL 8 mm Reverse Mount Probes

330105-02-12-CXX-DXX-EXX, 3/8-24 UNF threads<sup>2</sup>

330106-05-30-CXX-DXX-EXX, M10 x 1 threads<sup>2</sup>

#### Option Descriptions

##### C: Total Length Option

05	0.5 metre (1.6 feet)
10	1.0 metre (3.3 feet)
15	1.5 metre (4.9 feet)
20	2.0 metres (6.6 feet)
50	5.0 metres (16.4 feet)

---

**Note:** 5-metre probes are designed for use with the 5-metre Proximitor sensor only.

---

90 9.0 metres (29.5 feet)

##### D: Connector Option

02	Miniature ClickLoc coaxial connector
12	Miniature ClickLoc coaxial connector, FluidLoc cable

---

**Note:** The FluidLoc cable option –12 is not necessary on the vast majority of 330105 and 330106 installations due to the presence of the probe sleeve. Consider carefully the application before ordering the FluidLoc cable option for these probes.

---

##### E: Agency Approval Option

00	Not required
05	Multiple Approvals

---

### 3300 XL 8 mm Proximity Probes, Smooth Case:

330140 3300 XL 8 mm Probe without armor<sup>1</sup>

330141 3300 XL 8 mm Probe with armor<sup>1</sup>

Part Number-AXX-BXX-CXX-DXX

#### Option Descriptions

##### A: Overall Case Length Option

Order in increments of 0.1 in  
**Length configurations:**  
**Maximum length:** 9.6 in  
**Minimum length:** 0.8 in  
**Example: 2 4 = 2.4 in**

##### B: Total Length Option

05	0.5 metre (1.6 feet)
10	1.0 metre (3.3 feet)
15	1.5 metres (4.9 feet)
20	2.0 metres (6.6 feet)
50	5.0 metres (16.4 feet)

---

**Note:** 5-metre probes are designed for use with the 5-metre Proximitor sensor only.

---

90 9.0 metres (29.5 feet)

##### C: Connector and Cable-Type Option

01	Miniature coaxial ClickLoc connector with connector protector, standard cable
02	Miniature coaxial ClickLoc connector, standard cable
11	Miniature coaxial ClickLoc connector with connector protector, FluidLoc cable
12	Miniature coaxial ClickLoc connector, FluidLoc cable

##### D: Agency Approval Option

00	Not required
05	Multiple Approvals

---

### 3300 XL 8 mm Extended Temperature Range (ETR) Proximity Probes:

330191 3300 XL 8 mm ETR Probe, 3/8-24 UNF thread, without armor

330192 3300 XL 8 mm ETR Probe, 3/8-24 UNF thread, with armor

Part Number-AXX-BXX-CXX-DXX

##### A: Unthreaded Length Option

---

**Note:** Unthreaded length must be at least 0.8 inches less than the case length.

---

Order in increments of 0.1 in

##### Length configurations:

**Maximum unthreaded length:** 8.8 in

**Minimum unthreaded length:** 0.0 in

**Example: 1 5 = 1.5 in**

##### B: Overall Case Length Option

Order in increments of 0.5 in

##### Threaded length configurations:

**Maximum case length:** 9.6 in

**Minimum case length:** 0.8 in

**Example: 2 5 = 2.5 in**

##### C: Total Length Option

05	0.5 metre (1.6 feet)
10	1.0 metre (3.3 feet)
15	1.5 metre (4.9 feet)
20	2.0 metres (6.6 feet)
50	5.0 metres (16.4 feet)

---

**Note:** 5-metre probes are designed for use with the 5-metre Proximitor sensor only.

---

90 9.0 metres (29.5 feet)

##### D: Agency Approval Option

00	Not required
05	Multiple Approvals

---

**3300 XL 8 mm Extended Temperature Range (ETR) Proximity Probes, Metric:**

330193 3300 XL 8 mm Probe, M10 x 1 thread, without armor

330194 3300 XL 8 mm Probe, M10 x 1 thread, with armor

**Part Number-AXX-BXX-CXX-DXX**

A: Unthreaded Length Option

---

**Note:** Unthreaded length must be at least 20 mm less than the case length.

---

Order in increments of 10 mm.

**Length configuration:**

**Maximum unthreaded length:** 230 mm

**Minimum unthreaded length:** 0 mm

**Example: 0 6 = 60 mm**

B: Overall Case Length Option

Order in increments of 10 mm.

**Metric thread configurations:**

**Maximum length:** 250 mm

**Minimum length:** 20 mm

**Example: 0 6 = 60 mm**

C: Total Length Option

**0 5** 0.5 metre (1.6 feet)

**1 0** 1.0 metre (3.3 feet)

**1 5** 1.5 metres (4.9 feet)

**2 0** 2.0 metres (6.6 feet)

**5 0** 5.0 metres (16.4 feet)

---

**Note:** 5-metre probes are designed for use with the 5-metre Proximitor sensor only.

---

**9 0** 9.0 metres (29.5 feet)

D: Agency Approval Option

**0 0** Not required

**0 5** Multiple Approvals

---

**3300 XL 8 mm Extended Temperature Range (ETR) Reverse Mount Probes**

330195-02-12-CXX-DXX, 3/8-24 UNF threads

330196-05-30-CXX-DXX, M10 x 1 threads

C: Total Length Option

**0 5** 0.5 metre (1.6 feet)

**1 0** 1.0 metre (3.3 feet)

**1 5** 1.5 metre (4.9 feet)

**2 0** 2.0 metres (6.6 feet)

**5 0** 5.0 metres (16.4 feet)

---

**Note:** 5-metre probes are designed for use with the 5-metre Proximitor sensor only.

---

**9 0** 9.0 metres (29.5 feet)

D: Agency Approval Option

**0 0** Not required

**0 5** Multiple Approvals

---

**3300 XL 8 mm Extended Temperature Range (ETR) Proximity Probes, Smooth Case:**

330197 3300 XL 8 mm Probe without armor<sup>1</sup>

330198 3300 XL 8 mm Probe with armor<sup>1</sup>

**Part Number-AXX-BXX-CXX**

A: Overall Case Length Option

Order in increments of 0.5 in

**Length configurations:**

**Maximum length:** 9.5 in

**Minimum length:** 1.0 in

**Example: 3 5 = 3.5 in**

B: Total Length Option

**0 5** 0.5 metre (1.6 feet)

**1 0** 1.0 metre (3.3 feet)

**1 5** 1.5 metres (4.9 feet)

**2 0** 2.0 metres (6.6 feet)

**5 0** 5.0 metres (16.4 feet)

---

**Note:** 5-metre probes are designed for use with the 5-metre Proximitor sensor only.

---

**9 0** 9.0 metres (29.5 feet)

C: Agency Approval Option

**0 0** Not required

**0 5** Multiple Approvals

---

**Aluminum probe clamp bracket<sup>1</sup>**

137491-AXX

A: Mounting screw option

**0 1** 10-24 UNC-2A mounting screws

**0 2** M5 x 0.8-6g mounting screws

The aluminum clamp bracket is an unthreaded mounting bracket designed for use with the smooth case probes (330140, 330141, 330197 and 330198). After gapping the probe, tighten the clamp bracket by tightening the screws. The mounting screws have pre-drilled holes for safety wire.

---

**Aluminum probe threaded mounting bracket**

137492-AXX

A: Thread size

**0 1** 3/8-24

**0 4** M10 x 1

The aluminum probe threaded mounting bracket is the standard mounting bracket for most 3300 and 3300 XL probe installations. The **-01** option includes two 10-24 UNC-2A mounting screws. The **-04** option includes two M5 x 0.8-6g mounting screws. The mounting screws have pre-drilled holes for safety wire.

---

## Phenolic threaded probe mounting bracket

27474-AXX

A: Thread size

**01** 3/8-24

**04** M10 x 1

We recommend the phenolic threaded mounting bracket if your application requires additional electric isolation from the mounting location (as in some generator and electrical motor bearing locations). The **-01** option includes two 10-24 UNC-2A mounting screws. The **-04** option includes two M5 x 0.8-6g mounting screws. The mounting screws have pre-drilled holes for safety wire.

---

### Probe Ordering Information Notes:

1. Mounting clamps must be ordered separately for 330140, 330141, 330197, and 330198.
2. For a shorter delivery time, order commonly stocked probes. The following part numbers are currently stocked probes:

330101-00-08-05-02-00, 330101-00-08-05-02-05,  
330101-00-08-10-02-00, 330101-00-08-10-02-05,  
330101-00-12-10-02-00, 330101-00-12-10-02-05,  
330101-00-16-10-02-00, 330101-00-16-10-02-05,  
330101-00-20-05-02-00, 330101-00-20-10-02-00,  
330101-00-20-10-02-05, 330101-00-30-10-02-00,  
330101-00-30-10-02-05, 330101-00-40-05-02-00,  
330101-00-40-10-02-00, 330101-00-40-10-02-05,  
330101-00-60-10-02-00, 330101-00-60-10-02-05,  
330102-00-20-10-02-00, 330103-00-02-10-02-05,  
330103-00-04-10-02-00, 330103-00-05-10-02-00,  
330104-00-06-10-02-00, 330104-01-05-50-02-00,  
330105-02-12-05-02-00, 330105-02-12-05-02-05,  
330105-02-12-10-02-00, 330105-02-12-10-02-05,  
330106-05-30-05-02-00, 330106-05-30-05-02-05,  
330106-05-30-10-02-00, 330106-05-30-10-02-05.

---

---

## Ordering Information Extension Cables

---

### 3300 XL Standard Extension Cable

**330130-AXXX-BXX-CXX**

**Note:** Make sure that the extension cable length and the probe length, when added together, equal the Proximitor Sensor total length.

**A:** Cable Length Option

<b>030</b>	3.0 metres (9.8 feet)
<b>035</b>	3.5 metres (11.5 feet)
<b>040</b>	4.0 metres (13.1 feet)
<b>045</b>	4.5 metres (14.8 feet)
<b>070</b>	7.0 metres (22.9 feet)
<b>075</b>	7.5 metres (24.6 feet)
<b>080</b>	8.0 metres (26.2 feet)
<b>085</b>	8.5 metres (27.9 feet)

**B:** Connector Protector and Cable Option

<b>00</b>	Standard cable
<b>01</b>	Armored cable
<b>02</b>	Standard cable with connector protectors
<b>03</b>	Armored cable with connector protectors
<b>10</b>	FluidLoc cable
<b>11</b>	Armored FluidLoc cable
<b>12</b>	FluidLoc cable with connector protectors
<b>13</b>	Armored FluidLoc cable with connector protectors

**C:** Agency Approval Option

<b>00</b>	Not required
<b>05</b>	Multiple Approvals

---

## 3300 XL Extended Temperature Range (ETR) Extension Cable

**330190-AXXX-BXX-CXX**

**Note:** Make sure that the extension cable length and the probe length, when added together, equal the Proximitor Sensor total length.

**A:** Cable Length Option

<b>030</b>	3.0 metres (9.8 feet)
<b>035</b>	3.5 metres (11.5 feet)
<b>040</b>	4.0 metres (13.1 feet)
<b>045</b>	4.5 metres (14.8 feet)
<b>070</b>	7.0 metres (22.9 feet)
<b>075</b>	7.5 metres (24.6 feet)
<b>080</b>	8.0 metres (26.2 feet)
<b>085</b>	8.5 metres (27.9 feet)

**B:** Cable Option

<b>00</b>	Standard cable
<b>01</b>	Armored cable

**C:** Agency Approval Option

<b>00</b>	Not required
<b>05</b>	Multiple Approvals

---

## Ordering Information Proximito Sensor

---

### 3300 XL Proximito Sensor

#### 330180-AXX-BXX

##### A: Total Length and Mounting Option

- 10** 1.0 metre (3.3 feet) system length, panel mount
- 11** 1.0 metre (3.3 feet) system length, DIN mount
- 12** 1.0 metre (3.3 feet) system length, no mounting hardware
- 50** 5.0 metre (16.4 feet) system length, panel mount
- 51** 5.0 metre (16.4 feet) system length, DIN mount
- 52** 5.0 metre (16.4 feet) system length, no mounting hardware
- 90** 9.0 metres (29.5 feet) system length, panel mount
- 91** 9.0 metres (29.5 feet) system length, DIN mount
- 92** 9.0 metres (29.5 feet) system length, no mounting hardware

##### B: Agency Approval Option

- 00** Not required
- 05** Multiple approvals

---

**Accessories**

141078-01

**Manual.**

175751

**3300 XL Multi-Purpose Stainless Steel Housing.** 12"x12"x6". Can hold up to 8 Proximitors in a DIN-mount configuration or 6 Proximitors in a panel-mount configuration. (Available with ATEX Zone 0 and Zone 1 certifications.)

176467

**3300 XL Multi-Purpose Stainless Steel Housing.** 12"x8"x6". Can hold up to 4 3300XL Proximitors in both DIN-mount and panel-mount configurations. (Available with ATEX Zone 0 and Zone 1 certifications.)

330181

**3300 XL Multi-Purpose Stainless Steel Housing.** 13"x9.5"x7". Can hold up to 8 Proximitors in a DIN-mount configuration or 6 Proximitors in a panel-mount configuration. Primarily used by customers requiring hazardous area approvals from their installations. Available with ATEX Zone 0 and Zone 1 and North American Division 1 and Division 2 certifications.

02120015

**Bulk field wire.** 1.0 mm<sup>2</sup> (18 AWG), 3 conductor, twisted, shielded cable with drain wire. Specify length in feet.

138492-01

**Replacement panel-mount mounting pad.**

138493-01

**Replacement DIN-mount mounting pad.**

148722-01

**3300 XL test plug.** The 3300 XL Test Plug contains 3 small test pins attached to 3 color-coded 1-metre wires, each terminated in a banana plug. The 3-pin adapter plugs into the test pin holes on 3300 XL-style Proximitors. You can use this test plug to check the performance of the Proximitor sensor from the test pin holes in the terminal strip without removing the field wiring.

04310310

**3300 XL Proximitor Sensor panel-mount screw.** One 6-32 UNC thread forming mounting screw. Four screws are required for each Proximitor sensor. (Screws supplied standard with Proximitor housings [3300 XL panel-mount option]).

03200006

**Silicone self-fusing tape.** A 9.1-metre (10-yard) roll of silicone tape to protect connectors. This tape is easy to install and provides excellent electrical isolation and protection from the environment. We do not recommend using this tape inside the casing of the machine.

40113-02

**Connector Protector Kit.** Connector Protector Kit for 3300 XL 8 mm probes and extension cables, including connector protectors and installation tools.

136536-01

**Connector protector adapter.** This allows you to use connector protector installation tools manufactured prior to 1998 with 75Ω ClickLoc connectors.

40180-02

**Connector protectors.** Package contains 10 pairs of connector

protectors for 3300 XL 8 mm probes and extension cables.

**330153-09**

**03839410**

**75Ω triaxial male connector protector.** Male connector protectors install onto the extension cable and attach to the female connector protector on the probe, providing environmental protection of connectors.

**3300 XL ETR Connector Kit.** Used on ETR 3300 XL 8mm probes and 3300 ETR XL extension cables. Contains one pair of male and female ClickLoc connectors, two color-coded sleeves, two pieces of high temperature slit FEP tubing, and one strip of silicon tape.

**03839420**

**75Ω triaxial female connector protector.** Female connector protectors install onto the probe lead and attach to the male connector protector on the extension cable, providing environmental protection of connectors. You can also place the connector protector onto the extension cable to slide over the connection to the Proximitor sensor to protect that connection from the environment.

**163356**

**Connector Crimp Tool Kit.** Includes 1 set of multiconnector inserts and connector installation instructions. Compatible only with 330153 connector kits or with probes shipped in 2003 or later with ClickLoc connectors uninstalled. Supplied with carrying case.

**04301007**

**3/8-24 probe lock nut with safety wire holes.** Single probe lock nut with 2 holes drilled through the nut in order to secure the lock nut in place with safety wire.

**04301008**

**M10 x 1 probe lock nut with safety wire holes.** Single probe lock nut with 2 holes drilled through the nut in order to secure the lock nut in place with safety wire.

**330153-01**

**3300 XL connector kit.** Used on 3300 XL 8 mm probes and extension cables. Contains 1 pair each of male and female ClickLoc connectors, 2 color-coded sleeves, 2 pieces of slit FEP tubing, and 1 strip of silicone tape.

# Graphs

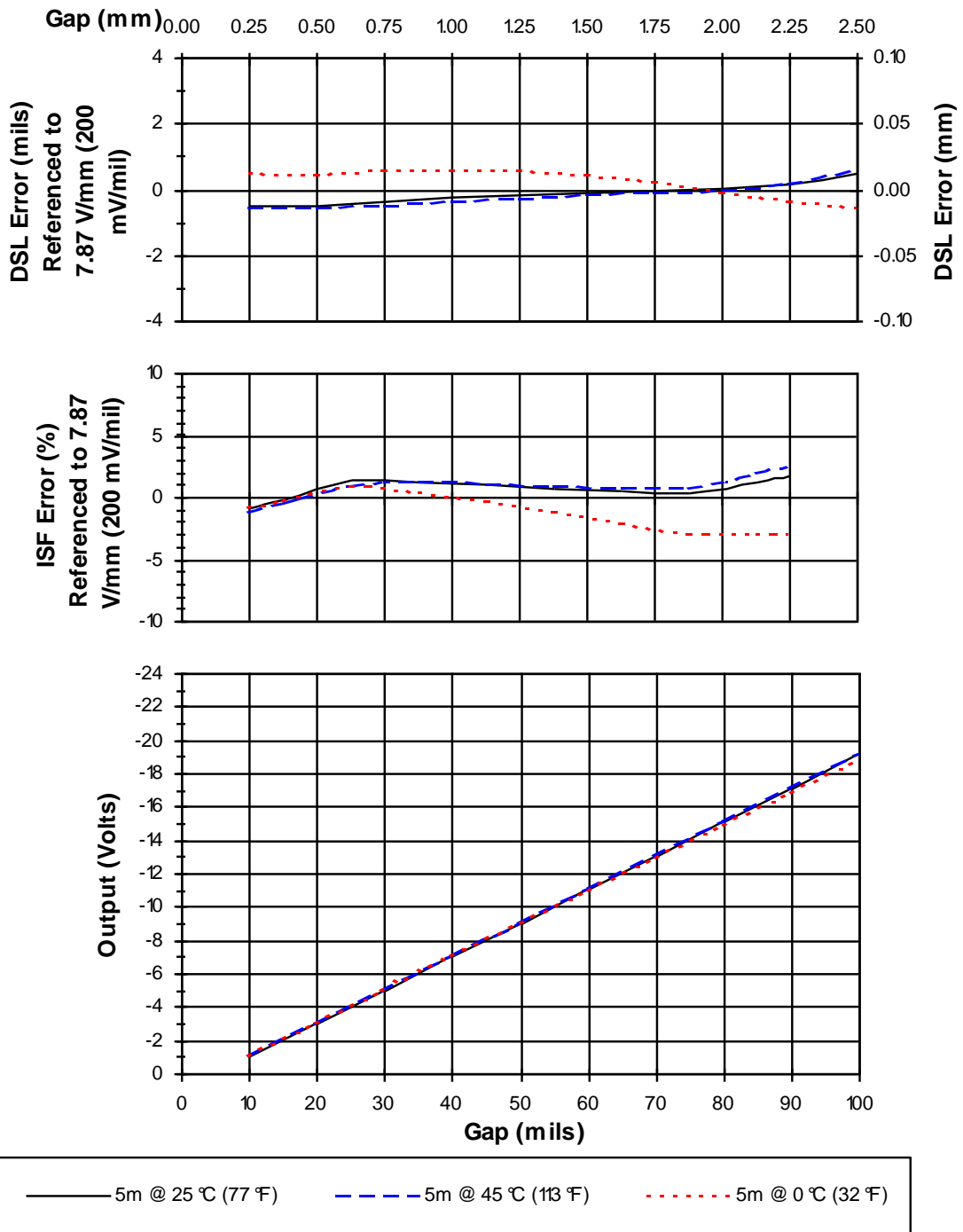

Figure 1: Typical 3300 XL 8 mm 5m or 1m System over API 670 Testing Range

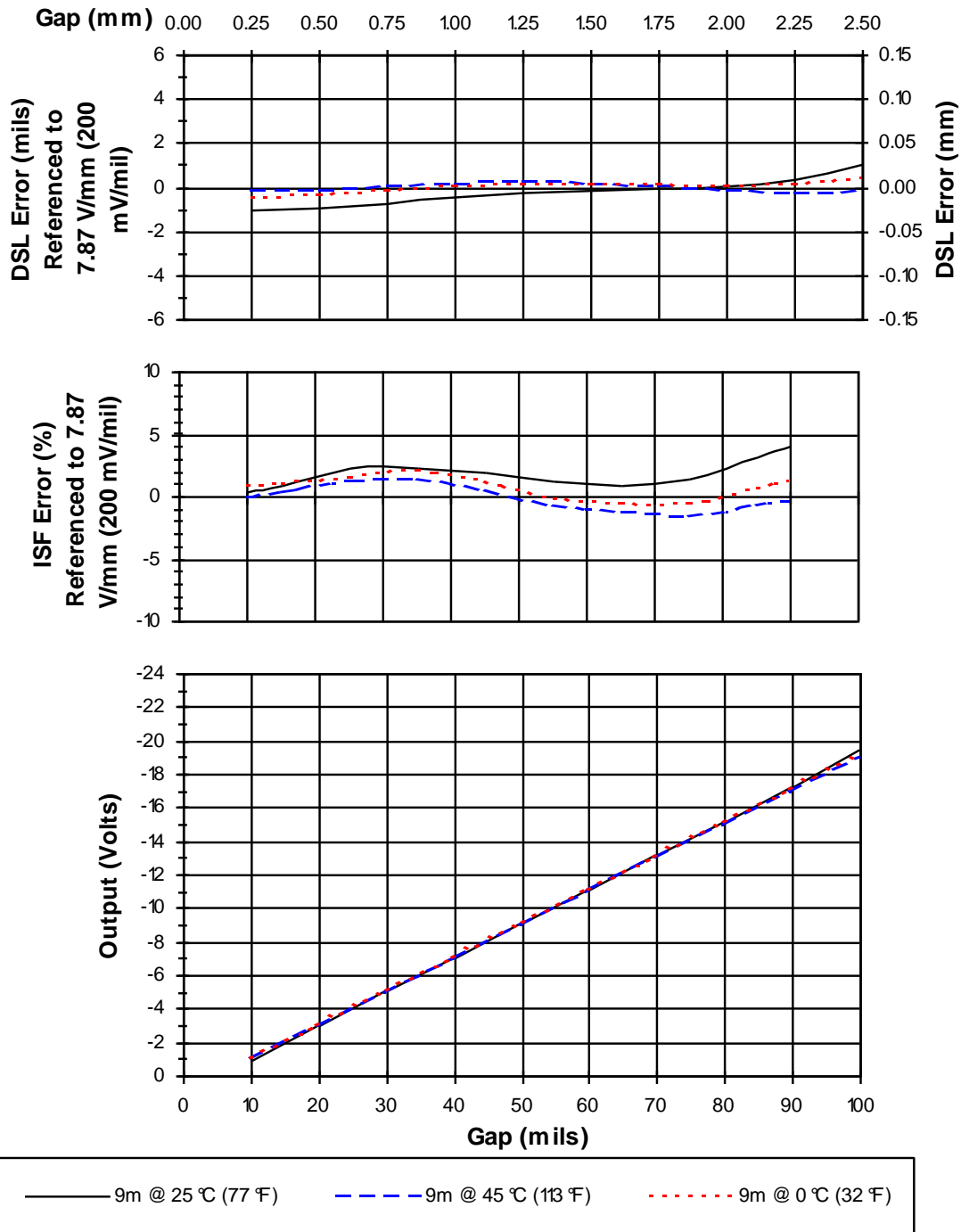

Figure 2: Typical 3300 XL 8 mm 9m System over API 670 Testing Range

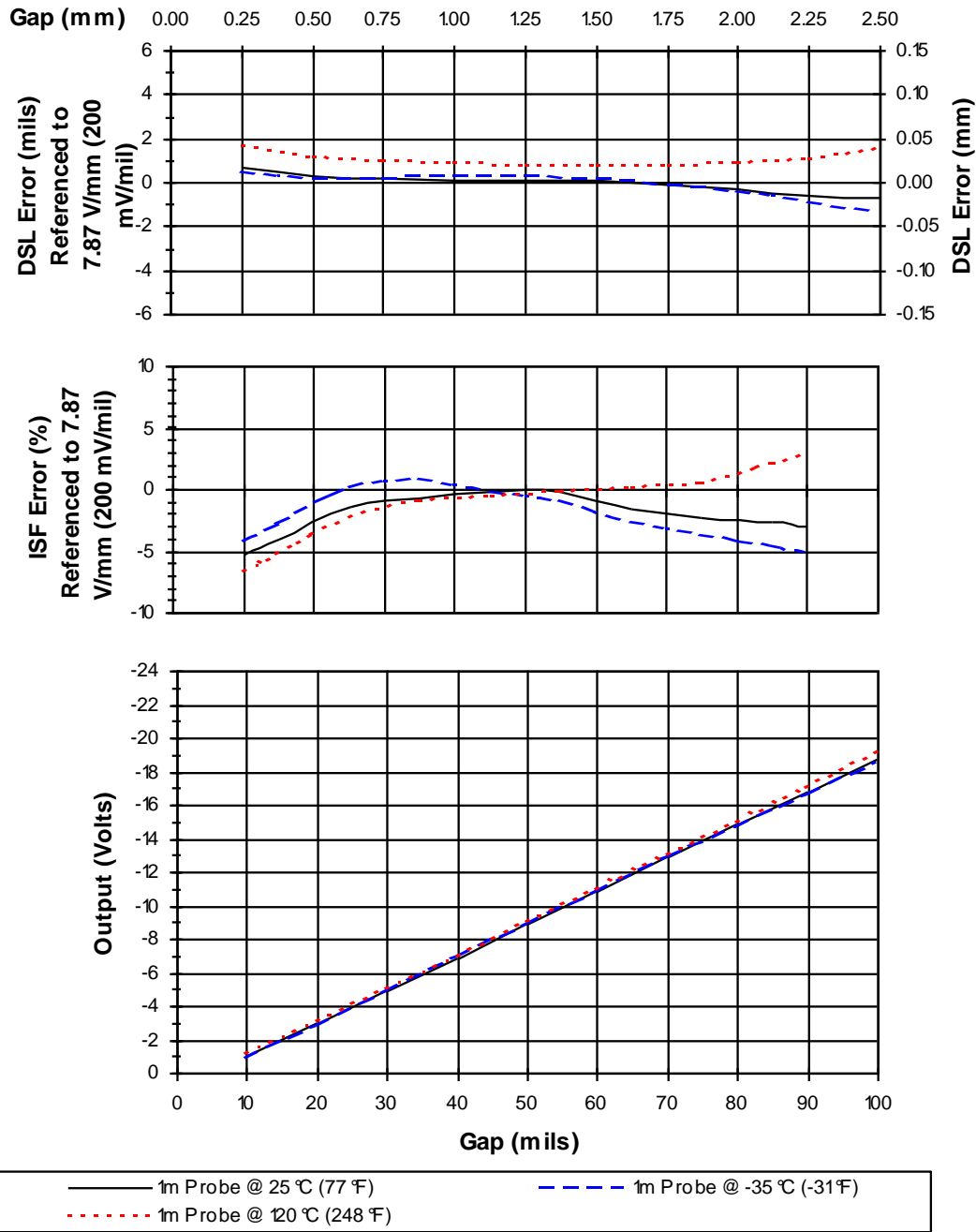

Figure 3: Typical 3300 XL 8mm Probe over API 670 Operating Range

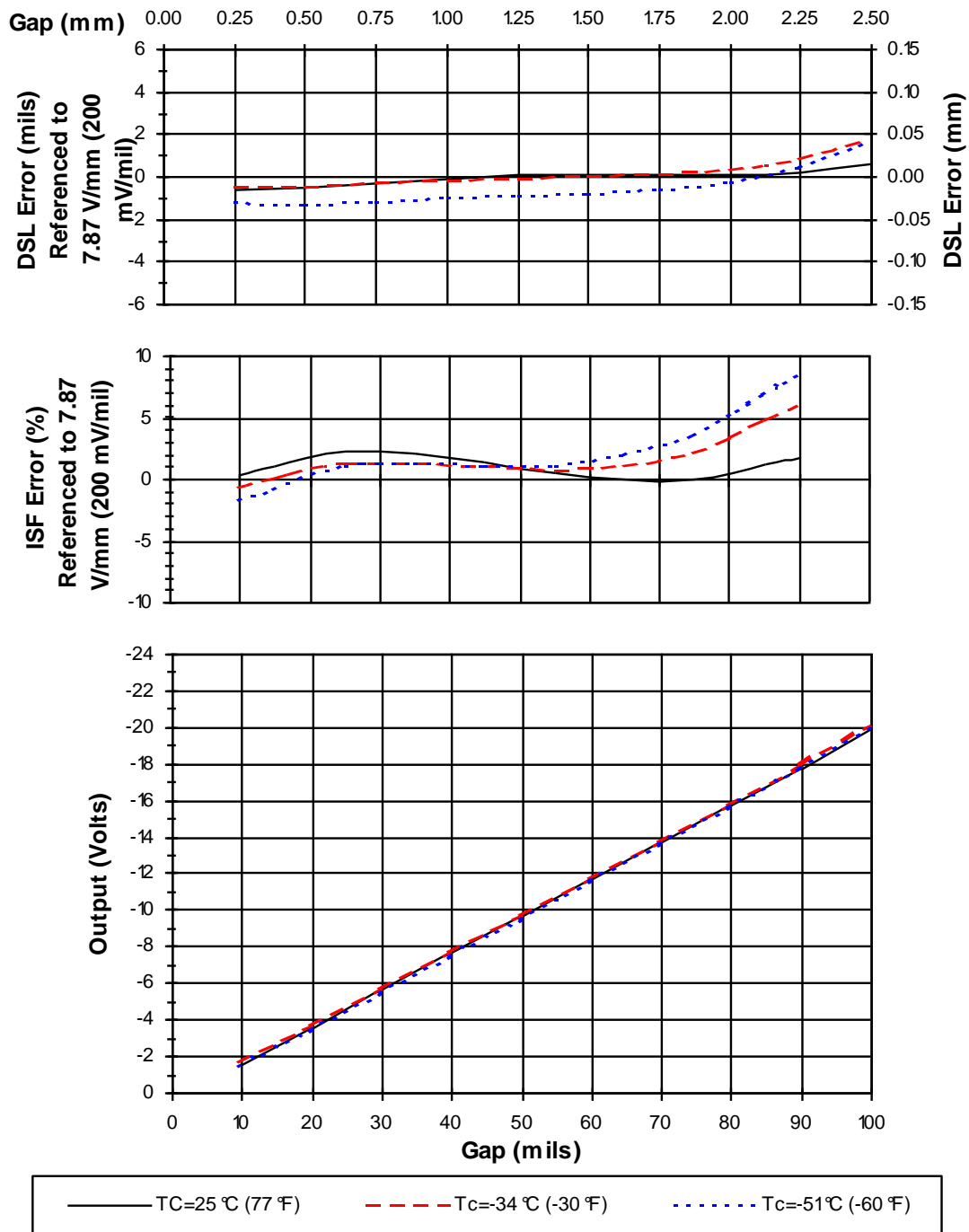

Figure 4: Typical 3300 XL 8 mm 5m Proximitor Sensor with 4m Extension Cable at  $T_c$  (Probe is at 25 °C)

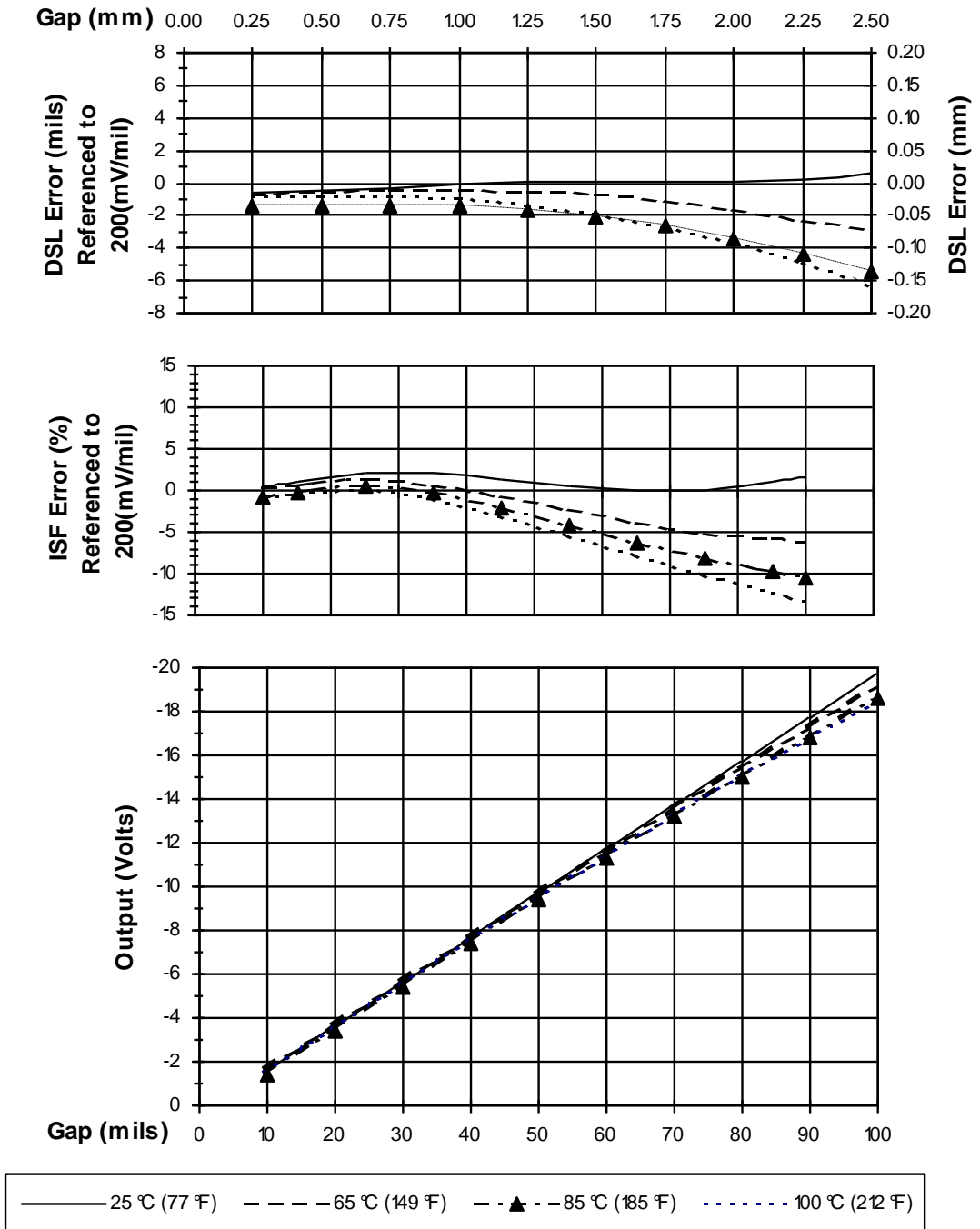

Figure 5: Typical 3300 XL 8 mm 5m Proximity Sensor with 4m Extension Cable at T<sub>h</sub> (Probe is at 25°C)

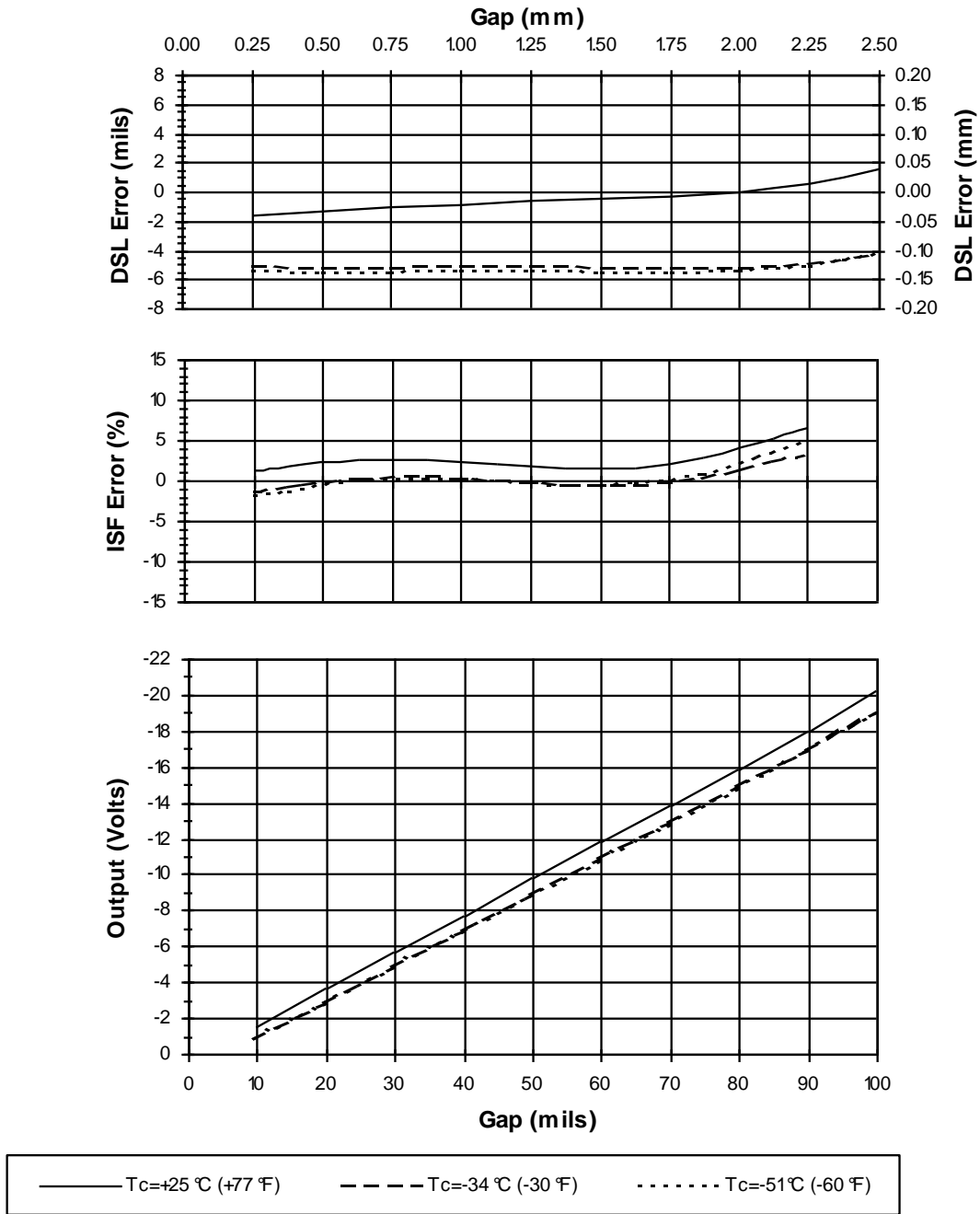

Figure 6: Typical 3300 XL 8mm 9 m Proximity Sensor with 8m of Extension Cable at  $T_c$  (Probe is at 25 °C)

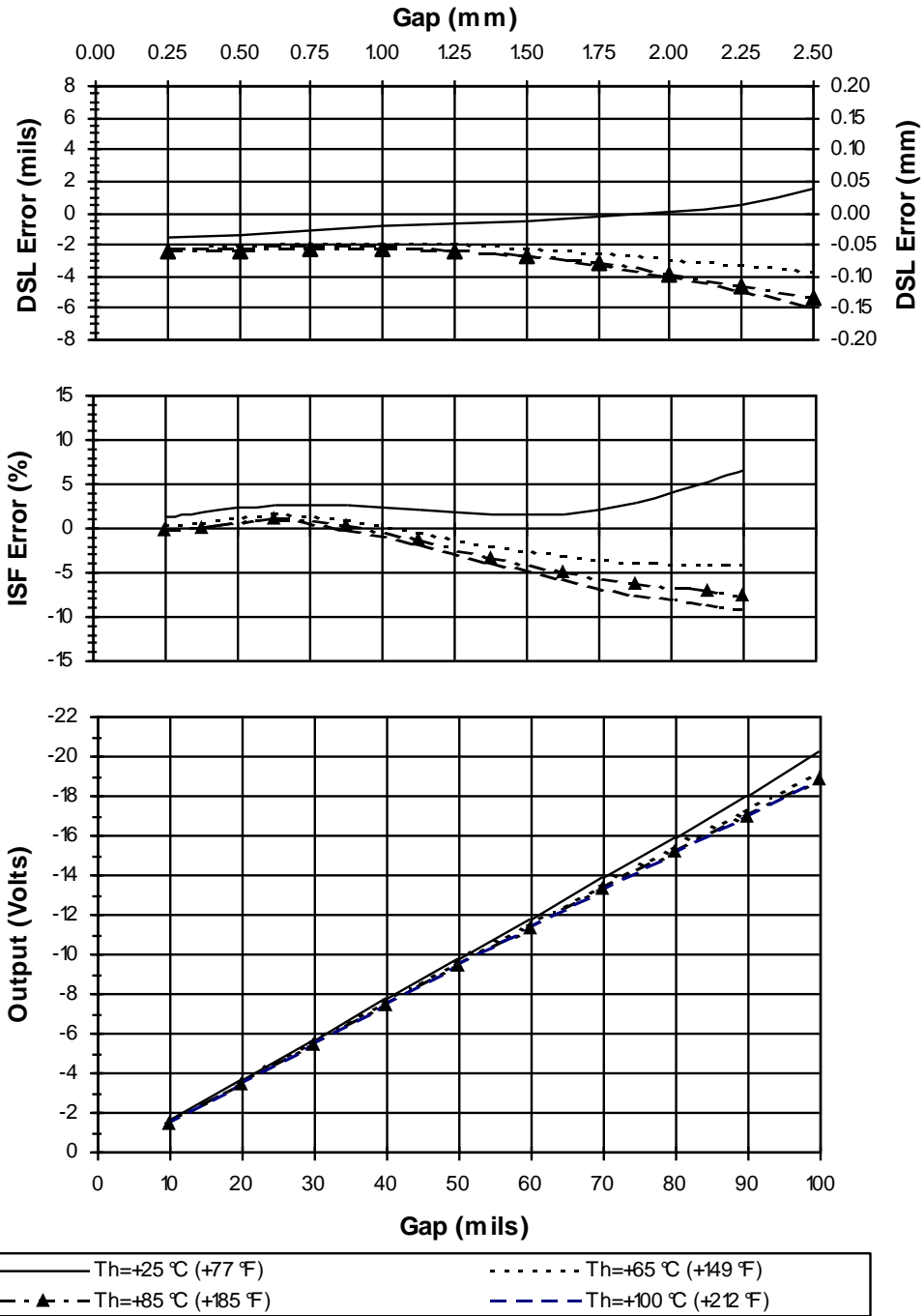

Figure 7: Typical 3300 XL 8mm 9m Proximity Sensor with 8m Extension Cable at  $T_h$  (Probe is at 25 °C)

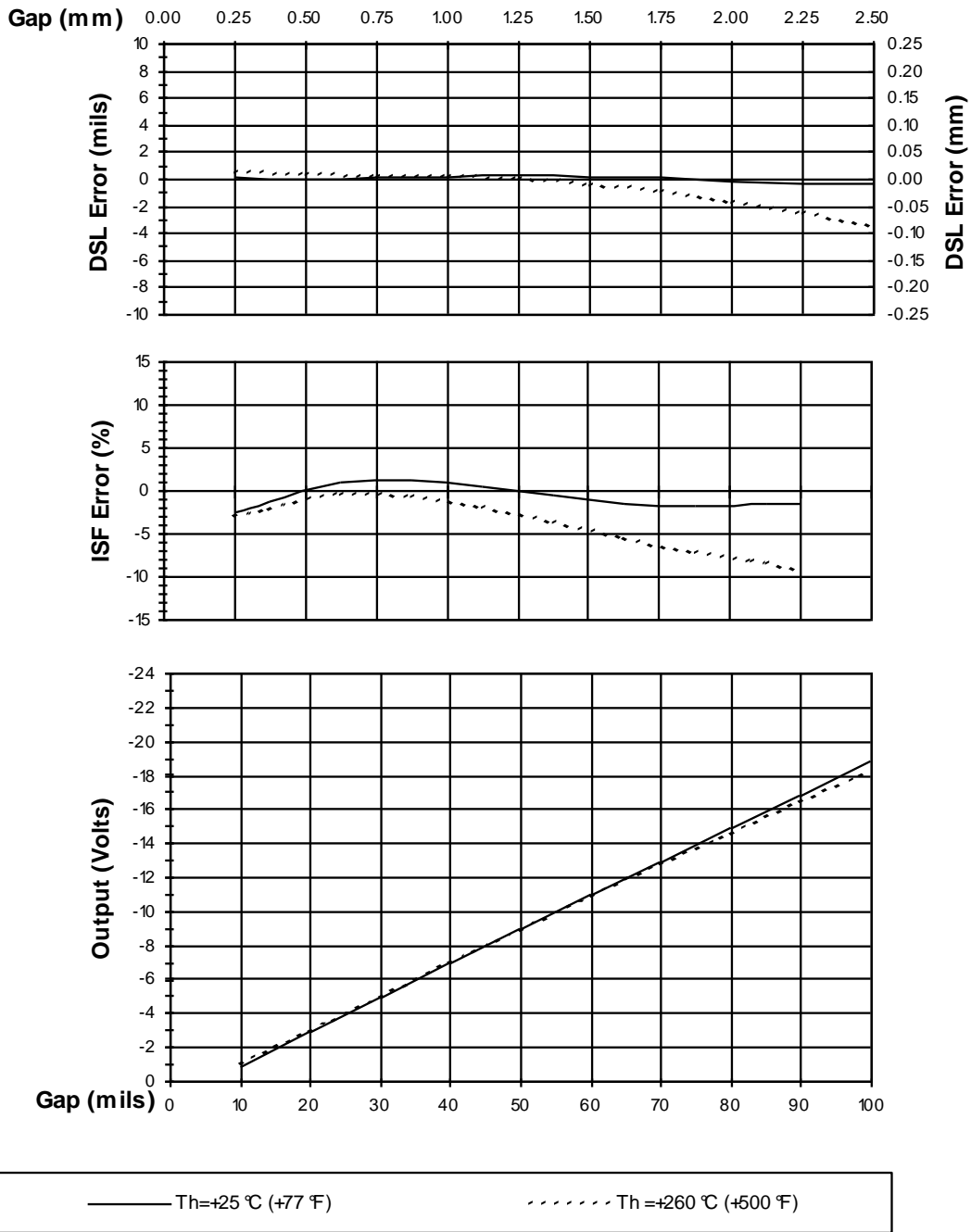

Figure 8: Typical 3300 XL Extended Temperature Range Probe and 4m Extended Temperature Range Extension Cable at  $T_h$  (Proximitor Sensor and Probe Tip with 1-foot Cable are at +25 °C)

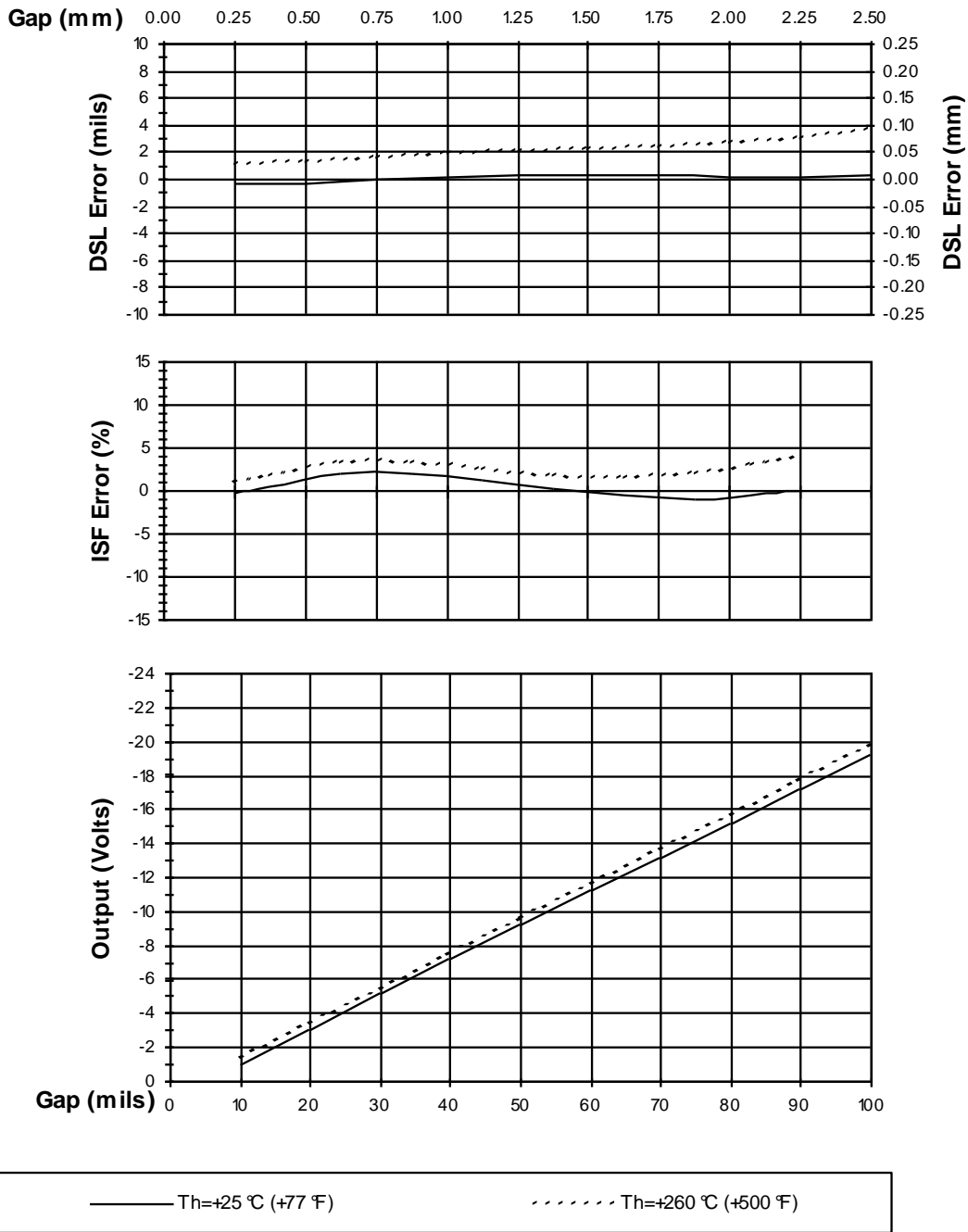

Figure 9: Typical 3300 XL Extended Temperature Range Probe and 8m Extended Temperature Range Extension Cable at  $T_h$  (Proximitor Sensor and Probe Tip with 1-foot Cable are at +25 °C)

### Frequency Response to Different Field Wiring Lengths without Barriers (5 m System)

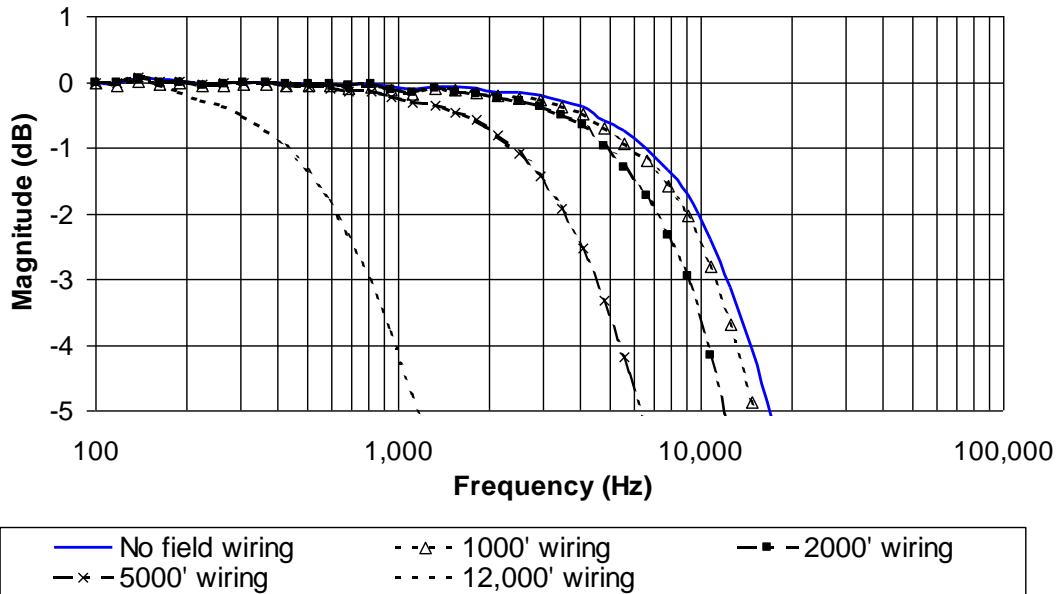

Figure 10: Frequency Response, Typical 3300 XL 8mm 5m or 1m System with Varying Lengths of Field Wiring Attached, No Barriers

### Phase Response with Different Field Wiring Lengths, No Barriers (5 m System)

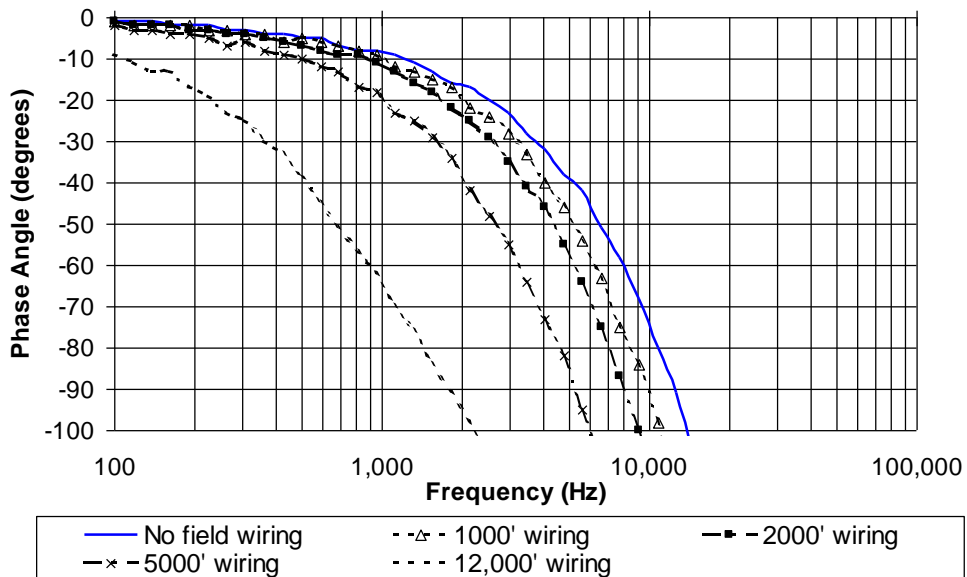

Figure 11: Phase Response, Typical 3300 XL 8mm 5m or 1m System with Varying Lengths of Field Wiring Attached, No Barriers

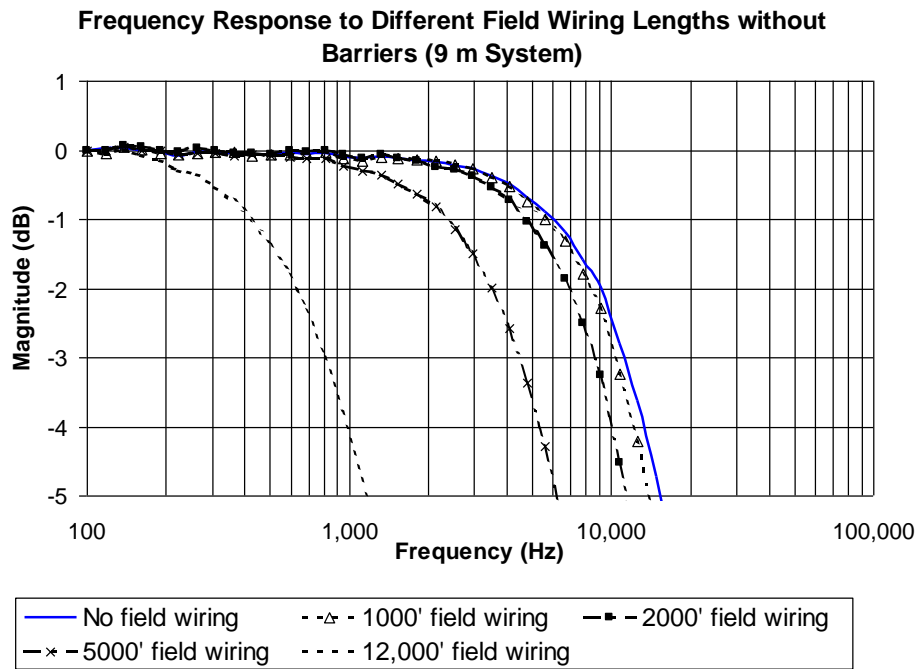

Figure 12: Frequency Response, Typical 3300 XL 8mm 9m System with Varying Lengths of Field Wiring Attached, No Barriers

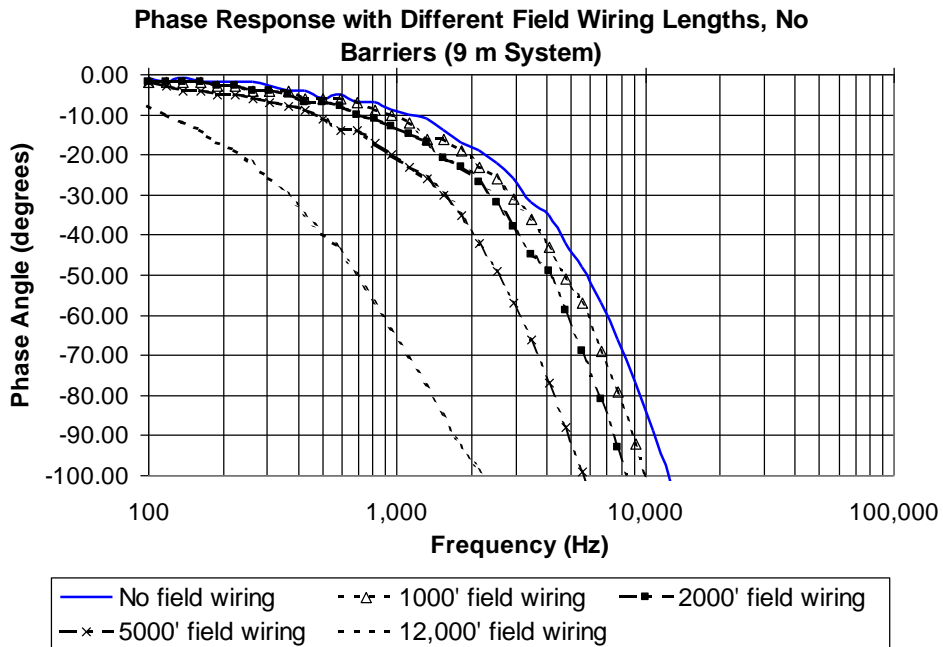
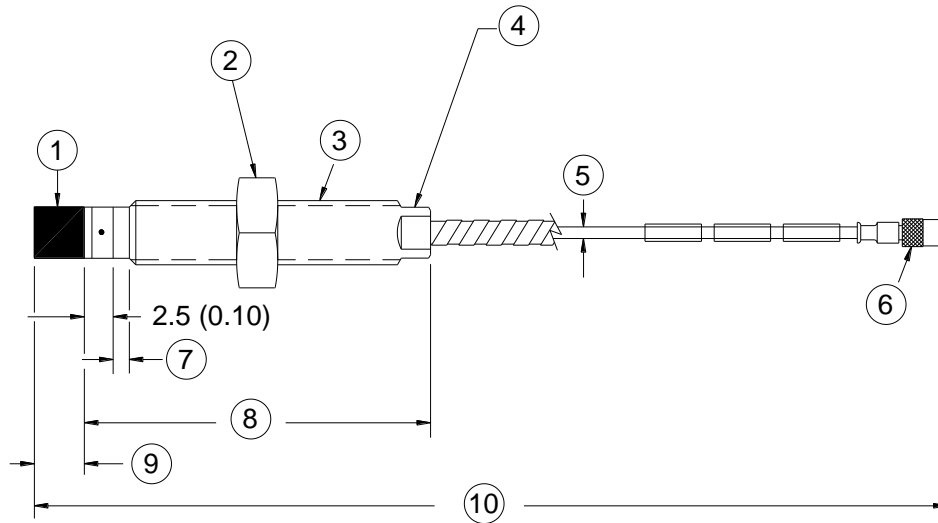

Figure 13: Phase Response, Typical 3300 XL 8mm 9m System with Varying Lengths of Field Wiring Attached, No Barriers

## Figures

Note: All dimensions shown in millimetres (inches) except as noted.



1. Probe tip, 8.0 mm (0.31 in) diameter
2. 9/16 in for 3/8-24 threads, M17 for M10 threads (see Note 2)
3. Case thread
4. 5/16 in wrench flats for 3/8-24 threads; 8mm wrench flats for M10 threads.
5. 75Ω cable, 3.68 mm (0.145 in) maximum outside diameter, 3.94 mm (0.155 in) maximum outside diameter for FluidLoc cable, 7.67 mm (0.302 in) outside diameter of armor, 9.5 mm (0.38 in) maximum diameter of armor ferrule
6. Miniature male coaxial connector, 7.24 mm (0.285 in) maximum outside diameter "D"
7. Unthreaded length "A"
8. Case length "B"
9. 6.0 mm (0.235 in) maximum
10. Total length "C", +30%, -0%<sup>3</sup>

**Figure 14: 3300 XL 8mm Proximity Probes, Standard Mount**

330101 and 330191, 3/8-24 UNF-2A, without armor <sup>7</sup>

330102 and 330192, 3/8-24 UNF-2A, with armor <sup>6</sup>

330103 and 330193, M10X1 thread, without armor <sup>7</sup>

330104 and 330194, M10X1 thread, with armor <sup>6</sup>

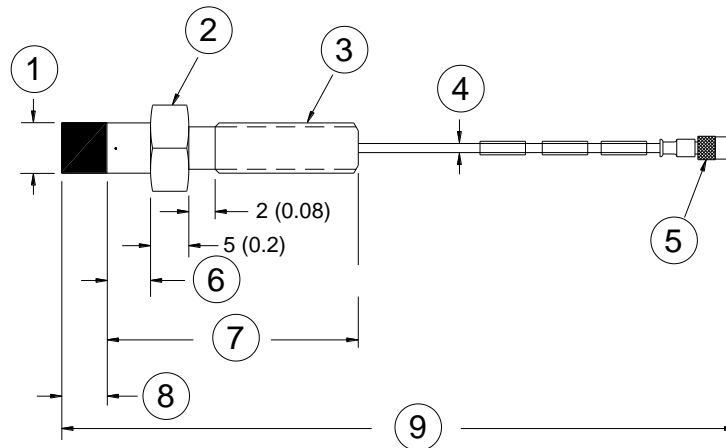

1. Probe tip, 8.0 mm (0.31 in) diameter
2. 7/16 in or M10 hexagonal
3. Case thread
4. 75Ω cable, 3.68 mm (0.145 in) outside diameter
5. Miniature male coaxial connector, 7.24 mm (0.285 in) maximum outside diameter "D"
6. Unthreaded length "A", 5.0 mm (0.20 in)
7. Case length "B", 30 mm (1.2 in)
8. 6.0 mm (0.235 in) maximum
9. Total length "C", +30%, -0%<sup>3</sup>

**Figure 15: 3300 XL 8mm Proximity Probes, Reverse Mount 4, 7**

330105 and 330195, 3/8-24 UNF-2A threads

330106 and 330196, M10X1 threads

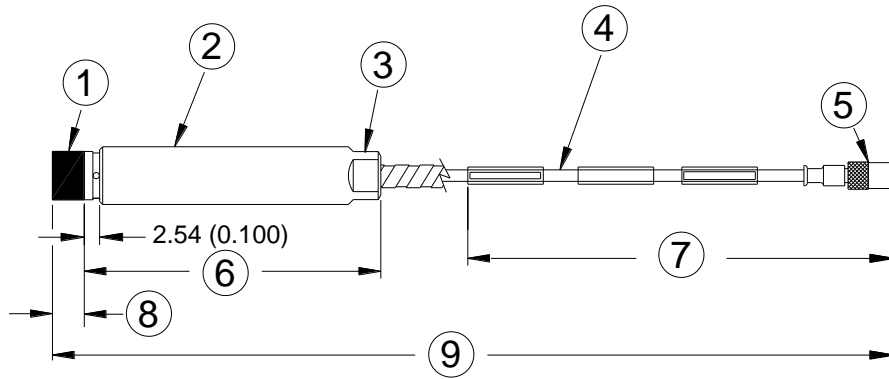

1. Probe tip, 8 mm (0.31 in) diameter
2. 9.66 mm (0.38 in) maximum diameter
3. 5/16 in wrench flats, 4 each
4. 75Ω cable, 3.68 mm (0.145 in) maximum diameter, 3.94 mm (0.155 in) maximum diameter for FluidLoc cable, 7.67 mm (0.302 in) outside diameter with armor, 10.2 mm (0.4 in) maximum diameter for armor ferrule
5. Miniature male coaxial connector, 7.24 mm (0.285 in) maximum outside diameter "D"
6. Case length "A",
7. 349.3 (13.75) max. distance
8. 6.0 mm (0.235 in) maximum
9. Total length "C", +30%, -0%<sup>3</sup>

**Figure 16: 3300 XL 8mm Proximity Probes, Smooth Case**

330140 and 330197, without armor <sup>7</sup>

330141 and 330198, with armor <sup>6</sup>

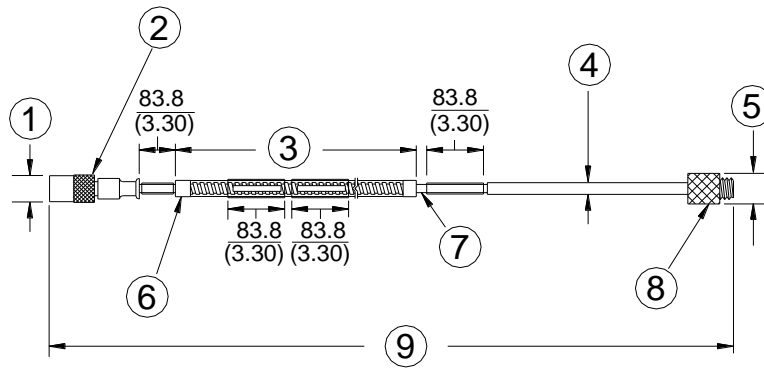

1. 7.24 mm (0.285 in) maximum diameter
2. Miniature male coaxial connector
3. FEP or PFA coated armor, armor length 300 mm (11.8 in) less than cable length (see Note 6)
4. 75Ω cable, 3.7 mm (0.15 in) maximum outside diameter, 3.94 mm (0.155 in) maximum diameter for FluidLoc cable, 7.67 mm (0.302 in) maximum outside diameter of armor, 10.2 mm (0.40 in) maximum diameter of armor ferrule
5. 7.24 mm (0.285 in) maximum diameter
6. Stainless steel ferrules, 10.2 mm (0.40 in) max diameter
7. FEP or PFA insulated triaxial cable
8. Miniature female coaxial connector
9. Cable length, +20%, -0%

**Figure 17: Extension Cable without Connector Protectors**

330130, 3300 XL Extension Cable (FEP Armor and Insulation)

330190, 3300 XL ETR Extension Cable (PFA Armor and Insulation)

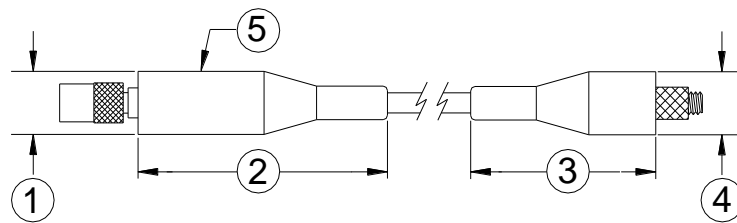

1. 12.4 mm (0.49 in) maximum diameter
2. 51.1 mm (2.01 in) maximum
3. 36.3 mm (1.43 in) maximum.
4. 12.4 mm (0.49 in) maximum diameter
5. Connector protector (fluorosilicone material)

**Figure 18: Extension Cable with Connector Protectors**

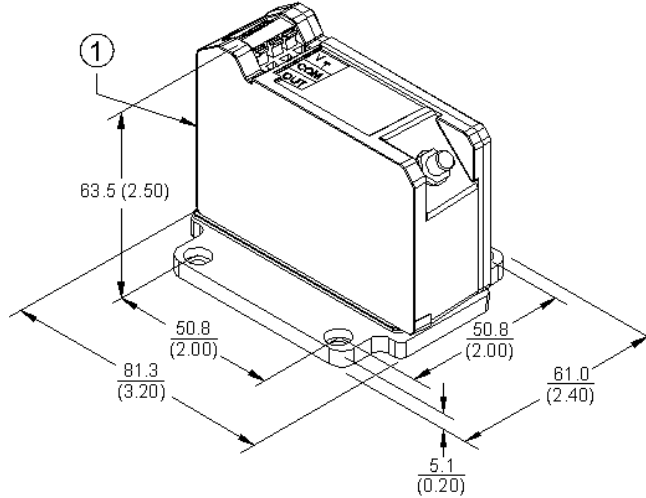

1. Mounting option "A", Options -50 or -90

**Figure 19: Panel Mount 3300 XL Proximity Sensor**

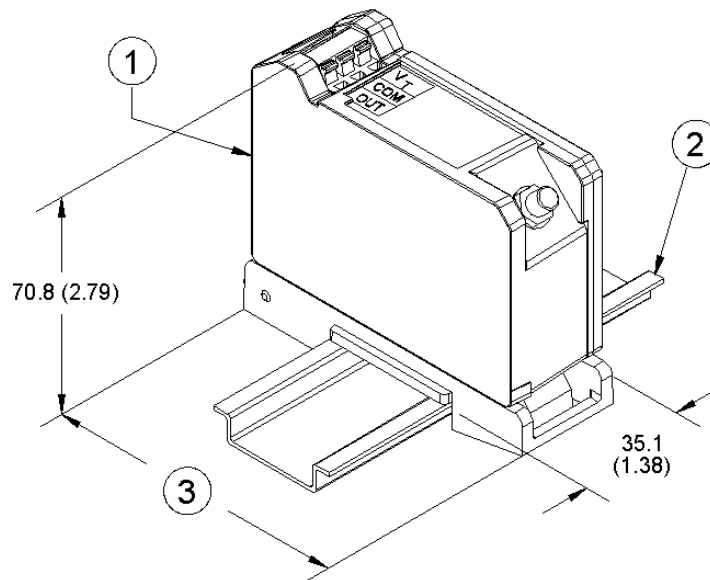

1. Mounting option "A", Options -51 or -91
2. 35mm DIN rail (not included)
3. 89.4 mm (3.52 in). Additional 3.05 mm (0.120 in) clearance required to remove DIN rail.

**Figure 20: DIN Mount 3300 XL Proximity Sensor**

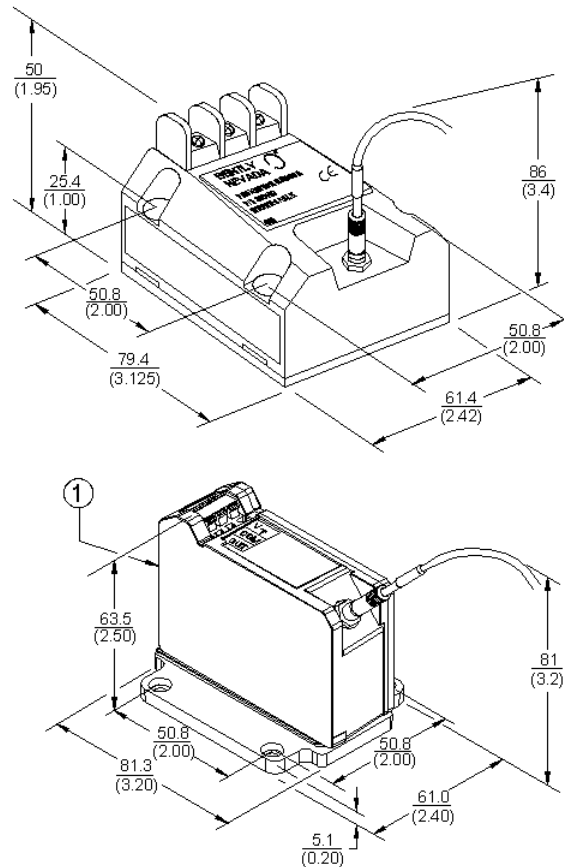

1. Mounting option "A", Options -50 or -90

**Figure 21: Physical Mounting Characteristics Showing Interchangeability of 3300 and 3300 XL Proximitor Sensors when 4-hole Mounting Option Is Used<sup>8</sup>**

**Figure Notes:**

1. All dimensions on figures are in millimetres (inches) unless otherwise noted.
2. Standard mount 8 mm probes supplied with M17 or 9/16 inch lock nut.
3. Probes ordered with 5 or 9 metre integral cables have a length tolerance of +20%, -0%.
4. Reverse mount probes not available with armor or connector protector options.
5. Letters inside quotation marks on figures refer to probe ordering options.
6. Stainless steel armor is supplied with FEP outer jacket for standard probes, PFA outer jacket for ETR probes.
7. FEP jacket is standard non-armored portion of the cable for standard probes, PFA jacket on non-armored portion for ETR probes.
8. Use M3.5 or #6 screws for panel-mount Proximitor Sensors (screws provided when purchasing Bently Nevada housings).

\* Denotes a trademark of Bently Nevada, Inc., a wholly owned subsidiary of General Electric Company.

Viton is a trademark of E. I. Du Pont de Nemours and Company.

© 1999-2011 Bently Nevada, Inc. All rights reserved.

Printed in USA. Uncontrolled when transmitted electronically.

1631 Bently Parkway South, Minden, Nevada USA 89423

Phone: 775.782.3611 Fax: 775.215.2873

[www.ge-mcs.com/bently](http://www.ge-mcs.com/bently)

# Velocity Sensor

## 5485C Datasheet



Integral Cable Configuration



Removable Cable Configuration



The Metrix 5485C is a moving-coil velocity transducer, specifically designed for continuous use in elevated temperatures. A zero-friction coil suspension provides accurate, repeatable vibration measurements over a wide range of amplitude and frequency and is built to withstand the high-g environments and cross-axis vibrations typical of gas turbines. The coil bobbin is suspended by two non-twisting, circular spider springs that provide a clean frequency response. Purely viscous electromagnetic damping is employed and eliminates friction-prone air damping. This allows improved detection of small vibration amplitudes at low frequencies.

The sensor is available in two configurations: with integral armored cable or removable armored cable via a 2-pin MIL-style threaded connector. The case is constructed of stainless steel and its robust internals are hermetically sealed to ensure durability in the most hostile environments. The product is approved for use in Zone 2 / Div 2 hazardous areas without use of intrinsic safety barriers. It is also approved for use in Zone 0/1 and Div. 1 areas with use of an appropriate intrinsic safety barrier.

### APPLICATIONS

- Gas Turbines
- Furnace Fans
- Machines with continuous or intermittent surface temperatures above 120° C

### FEATURES

- Self-generating, no power required
- Native velocity output – handles impulsive signals better than integrated accelerometers
- Stainless steel housing
- Eliminates friction-prone air damping
- Analog performance delivers excellent resolution
- Approved for use in hazardous areas
- Available with integral or removable cable

### SPECIFICATIONS

Axis Orientation	Any
Sensitivity	105, 145, 150, or 200 mV/in/sec (see ordering options)
Sensitivity vs. Temperature	Less than 0.02%/°C
Cross-Axis Sensitivity	Less than 10%
Service Temperature	-54 to + 375 ° C (-65 to +707 ° F)
Frequency Response	(-3dB) 15 Hz to 2000 Hz
Maximum g-level	50g
Maximum Displacement	1.8 mm (70 mils) pk-pk
Case-to-Coil Isolation (min)	100 MΩ @ 20° C 10 MΩ @ 200° C 1 MΩ @ 375° C
Case Sealing	Welded; heretically sealed
Material	Housing: 416 Stainless Steel Connector: 316 Stainless Steel Cable Armor: 302 Stainless Steel
Weight	Sensor: 0.2 kg (0.5 lb) Armored Cable: 0.2 kg/m (0.13 lb/ft)
Connector Type	Sensor: 2-pin MIL-style* (male) 4850 Cable: 2-pin MIL-style* (female) Integral Cable: none (cable is not detachable)

\* This connector is specific to high-temperature velocity sensors and removable cables. If the 5485C is to be connected to other instrumentation, the integral and removable cables terminate in flying leads (see Figures 1 and 2) allowing user installation of other connector types as required.

### APPROVALS

CE Mark	Yes
CSA	Class I, Groups A-D <sup>1</sup> (intrinsically safe) Class I, Groups C-D <sup>2</sup> (explosion-proof) Class I, Div 2, Groups A-D <sup>3</sup> (non-incendive)
IECEX	Ex ia IIC T* Ga <sup>1,4</sup> (intrinsically safe) Ex na IIC T (non-incendive)
ATEX	
UL	Class I, Groups A-D <sup>1</sup> (intrinsically safe) Class I, Div 2, Groups A-D <sup>3</sup> (non-incendive)
GOST-R and GOST-K	Ex ia IIC T* Ga <sup>1,4</sup> (intrinsically safe)

#### Notes:

- Intrinsically safe when installed with appropriate intrinsic safety barrier per Metrix drawing 7623.
- Explosion-proof when installed in housing (XXXX) and wired through rigid conduit directly to monitor in safe area.
- Non-incendive when installed per Metrix drawing 8096.
- Temperature Classification (T\*) for the 5485C varies as a function of the ambient temperature. Essentially, the 5485C's surface temperature will not rise more than 40° C above its ambient surroundings, up to its rated maximum operating temperature of 375° C. See table below.

Ambient Temperature (Ta)	Temp. Classification
-54° C ≤ Ta ≤ +45° C	T6
-54° C ≤ Ta ≤ +60° C	T5
-54° C ≤ Ta ≤ +95° C	T4
-54° C ≤ Ta ≤ +160° C	T3
-54° C ≤ Ta ≤ +260° C	T2
-54° C ≤ Ta ≤ +375° C	T1

### ORDERING INFORMATION

Removable Cable Version  
(Requires Cable 4850, Ordered Separately)  
5485C-AAA

A	A	A	OUTPUT TYPE
0	0	2	105 mV/in/s (4.14 mm/sec), 73 Ω coil resistance
0	0	4	145 mV/in/s (5.71 mm/sec), 102 Ω coil resistance
0	0	6	200 mV/in/s (7.87 mm/sec), 135 Ω coil resistance
0	0	8	150 mV/in/s (5.91 mm/sec), 105 Ω coil resistance

Integral Cable Version (cable 4850 not required)  
5485C-AAA-BBB

A	A	A	OUTPUT TYPE
0	0	1	105 mV/in/s (4.14 mm/sec), 73 Ω coil resistance
0	0	3	145 mV/in/s (5.71 mm/sec), 102 Ω coil resistance
0	0	5	200 mV/in/s (7.87 mm/sec), 135 Ω coil resistance
0	0	7	150 mV/in/s (5.91 mm/sec), 105 Ω coil resistance
B	B	B	CABLE LENGTH (in feet)
0	1	0	10 feet (3 m)
0	2	0	20 feet (6.1 m)
0	6	0	60 feet (18.3 m)
X	X	X	Other lengths in feet; min length 2 feet; max length 60 feet; must be ordered in 2-foot increments (e.g., AAA=042 for 42' length is allowed; AAA=043 for 43' length is not allowed)

High-Temperature Armored Cable Assembly  
4850-AAA

A	A	A	CABLE LENGTH (in feet)								
0	1	0	10 feet (3 m)								
0	2	0	20 feet (6.1 m)								
0	6	0	60 feet (18.3 m)								
X	X	X	Other lengths in feet; min length 2 feet; max length 100 feet; allowable ordering length increments summarized below:								
			<table border="1"> <thead> <tr> <th>Cable Length</th> <th>Allowable Increments</th> </tr> </thead> <tbody> <tr> <td>2 – 20 feet</td> <td>1 foot (e.g., AAA=018 for 18' and AAA=019 for 19')</td> </tr> <tr> <td>20 – 60 feet</td> <td>2 feet (e.g., AAA=042 for 42' and AAA=044 for 44')</td> </tr> <tr> <td>60 – 100 feet</td> <td>5 feet (e.g., AAA=075 for 75' and AAA=080 for 80')</td> </tr> </tbody> </table>	Cable Length	Allowable Increments	2 – 20 feet	1 foot (e.g., AAA=018 for 18' and AAA=019 for 19')	20 – 60 feet	2 feet (e.g., AAA=042 for 42' and AAA=044 for 44')	60 – 100 feet	5 feet (e.g., AAA=075 for 75' and AAA=080 for 80')
Cable Length	Allowable Increments										
2 – 20 feet	1 foot (e.g., AAA=018 for 18' and AAA=019 for 19')										
20 – 60 feet	2 feet (e.g., AAA=042 for 42' and AAA=044 for 44')										
60 – 100 feet	5 feet (e.g., AAA=075 for 75' and AAA=080 for 80')										

### ACCESORIES

#### 8531-AAA 4-hole to 1/4"-28 UNF mounting stud adapter kit

A			ATTACHMENT TYPE
0	0	1	Shipped loose
0	0	2	Shipped pre-attached to 5485C sensor

Allows 5485C to be mounted on a 1" diameter machined flat spot with in a 1/4-28 UNF tapped hole in the center. Adapter includes mounting plate, 1/4-28 stud, and four 8-32 cap screws / lock washers. Material: 303 stainless steel.



8531 ADAPTER  
(INSTALLED)



8531 ADAPTER  
(LOOSE)

